



Remote Viewing Area51.

A Target/Project tasked by Courtney Brown at Farsight, April-June 2017.

The enclosed remote Viewing paper sessions were created by Daz Smith during April to June 2017, before he moved onto whiteboard and recorded the data Live on video. The target was worked BLIND and the only prior information the remote viewers had was the number: Target16.

The tasking was for the viewers to look at the known location of Area51 and to report what they found.

Whatsapp group - <https://chat.whatsapp.com/CVpWa8JfBUHikCxKJvjGw>

Facebook - <https://www.facebook.com/groups/remoterviewers>

Telegram - https://t.me/joinchat/NvI6G1Q04YueN3q6i_t7Lg

Remoteviewed youtube: <https://www.youtube.com/channel/UCECjkD8Q1Vrj7x6cT-5fy2Q>

page: 1
TARLIST: 16.

Stage: 1

D.

30.4.17.

11.45 AM.

CRV

BLIND

SOLO.

Re: 15 min meditation to music - OK 😊



Land

HAER

CRUSTY.

DUSTY

and

Dry.

BARE.

UNEVEN.

WIDE-VISTA.

OPEN.

LAYERED.

ADL
DESOLATE.

yellow, oars, blue skies.

RUGGED LANDSCAPE.



A: across up, across.
Solid

B: Smeared.

SZ

HARD

DENSE.

SOLID

HARD EDGE

THIN

RISING

ABOVE ME.

DENSE

THICK.

CAD

RAISED.

MANMADE.

STEEL.

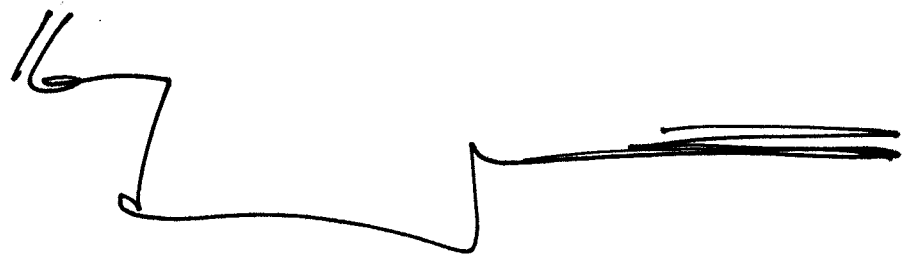

LAYERED.

LINEAR.

EDGED

REGATED.

AX
STEPS.

HARD

SOLID

DRY.

OLD

TEXTURED

SURFACE

AX
WAYS.

S_{1/2}: A SENSE OF RISING OR CREATED OF CURVED.

A STRONG FEEL OF A WINDWAVE OF THE LAND.

AC WIND, RUSTLE, VOICES

T: HARD/ROUGH, EDGED.

T2: WARM - COLD WIND.

V- Colors = Red, yellow, orange. Blue.

EM: BRIGHT - VERY.

CON: VERY HIGH.

T3: DUSKY/GAETHY.

AC
SUNNY
BRIGHT.

O: NATURAL.

AC
DESERT.

ES: PAST VIBRATIONS.

SUB: ENERGY.

D-

4 LAYERED

V. RISING, TALL.

D

MDSV: VERY HEAVY, SGT, THICK. ANNUAL
SPACED, ARRANGED.

AE: FEELS BEAUTIFUL. - BARE BONES - UNMISSED?

16

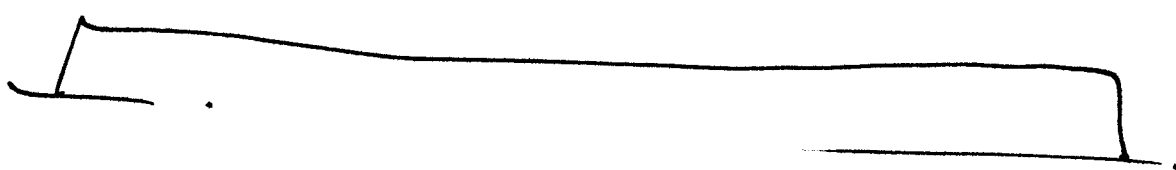

VERY LONG
 ANNULAR
 SHAPED.
 WATER EVIDENT.
 Solid
 structure.
 many maps

upon LAND
 from LAND

S4 1/2: THIS FEELS LIKE A MANMADE STRUCTURE OF THE
 LAND BUT ALSO IN THE LAND-

EMBEDDED?

THESE FEELS LIKE THERE ARE REPRESENTATIVE LAYERS TO
 THIS.



MOVE ABOVE THE TARGET - 150FT ABOVE - SKETCH
DESCRIBE IN FULL DETAIL - ONLY:

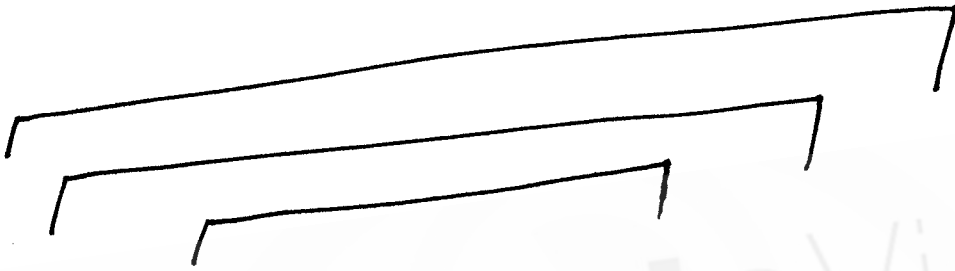
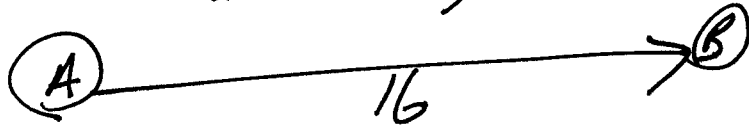

1. SENSE LINEAR/ANGULAR
SHAPES - FEELS MANMADE

- THIS FEELS SLIGHTLY LONGER. / QUIET.

- THIS ALL FEELS RAISED OR RISING OUT OF THE
LANDSCAPE. - BUT ALSO PART OF THE LANDSCAPE.

AC
CAMPAIGNED

page: 7.

Stage: 3

D.

MOVE TO THE MOST IMPORTANT POINT OF THE THREAT -
SKETCH/DESCRIBE IN FULL DETAIL - ONLY:

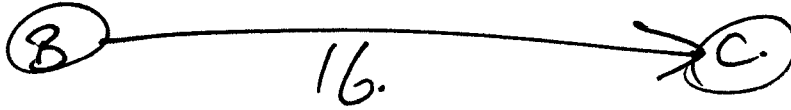

LINEAR
TALL.

RAISED

EDGE.

BOX.

ANNULAR.

STRAIGHT.

WALLS

SILLING..

SL4¹/₂: THIS FEELS LIKE A MANMADE - USED MORE IN
THE PAST - BUT ALSO USED NOW.

A SENSE OF SOMETHING LOST WITH THIS THREAT.
SOMETHING FEELS HAZY - OR FORGOTTEN.



ANALYTICAL

RISING

STEPPED

LINEAR.

SHARP EDGES, CUT, ORVED.

Abc
STONE.

St 1/2. I FEEL LIKE IM SEEING GLIMPSES OF ACUTE ANGLES.
THAT RECEED INTO THE DISTANCE.

Complex mix of SHAPES.
FUNCTIONS.

Abc
EXTREMUM

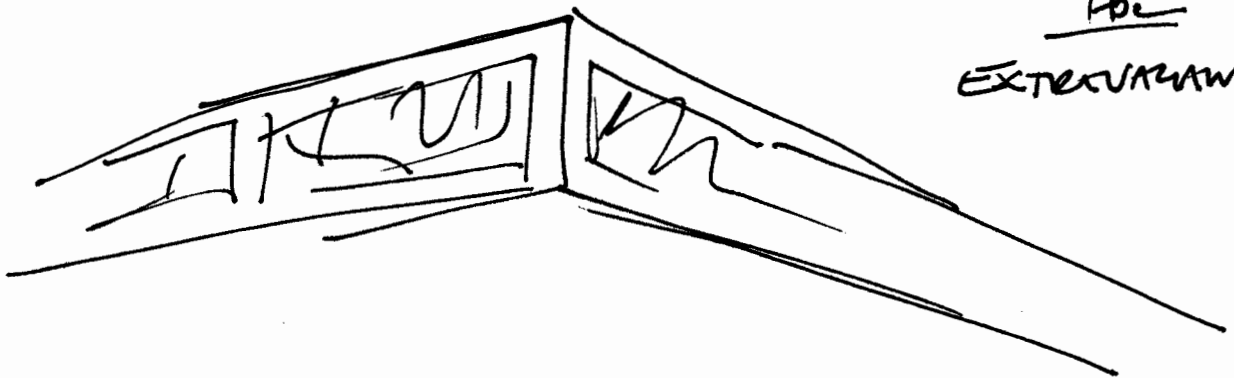

NOTE INSIDE THE TARGET - CENTRE - SKETCH / DESCRIBE IN FULL DETAIL:

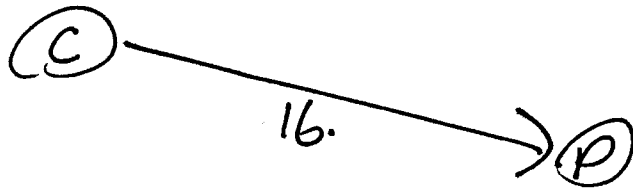

HARD
SOLID

DENSE.

DARK

COOL.

GRUDDY.

LINEAR.

DUSTY.

THERE IS AT LEAST ONE SPAGE. FEELS OLD / STUNNY, DIRTY.

THIS FEELS UNDER. THIS FEELS LIKE THERE IS A WEIGHT ABOVE / AROUND / ME.

I FEEL THAT TO FIND THE TRUE MEANING OF THIS TARGET I NEED TO LOOK BACKWARDS.

A HINT OF SOMETHING SECRETIVE / HIDDEN

S2 D AC EC T I AOL Ref.

INSIDE.

DENSE.

x

QUILT

MURKY

DARK.

MURKY

DUSTY.

HEAVY
FEELING

SLIP
DASH.

DECAYED.

NOT
QUITE
RIGHT?

S4 1/2

IT FEELS CRAMPED OR CLAUSTROPHOBIC HERE.

I SENSE THERE ARE SPACES - BUT IN BETWEEN

THE SPACES - ACTUAL SPACE IS VERY LIMITED LIKE

SMALL CHANNELS OR TUNNELS.

EVERYTHING FEELS ANGIULAR/LINEAR.

AOL
BLOCKS.

SZ D DE EC T L NQL HYS.

MOVE TO THE TASKS 'NEED' FROM THIS TARGET - SKETCH / DESCRIBE IN DETAIL ONLY:

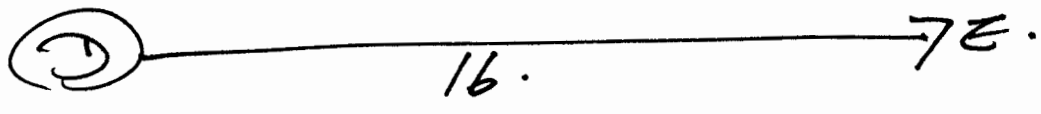

HARD
LINEAR.

COMPOSED
STRUCTURE

HARD
ARRANGED.

FIXED.

POSITIONAL

ST2: DISTANCE / PRESENTATION - SEEM IMPORTANT?

- THIS FEELS LIKE A PROTECTION / A PROTECTIVE PAGE FOR A SECRET - TO KEEP SOMETHING HIDDEN / PROTECTED.

Page: 12.

Stage: 4

D.

52

D

AC

EC

T

I

AL

Ref.

Purpose of this project:

Hidden
 Storage.
 Study.
 Research.
 Knowledge
 power
 Gain.

~~AL~~
 TEST
 SITE.

ARTIFACT

12.38pm

END.

 DAL.

page: 1.
TARGET: 16.

Stage: 1

D.

3.5.17.

1.50pm

CRU

BIRD

SOLO



LAYERS
LAND
DOWNWARDS
DRINK
CLOG
HEAVY
THICK
DENSE
LAYERS.

AP
STONE

GALENES.



DEEP.

SECTIONED
SPACES.

LAYERS.
ORGANISED.

DENSE
SAID

S1/2.

THIS FEELS LIKE AN ORGANISED SPACE.
AROUND A HUB - LIKE A NGST.

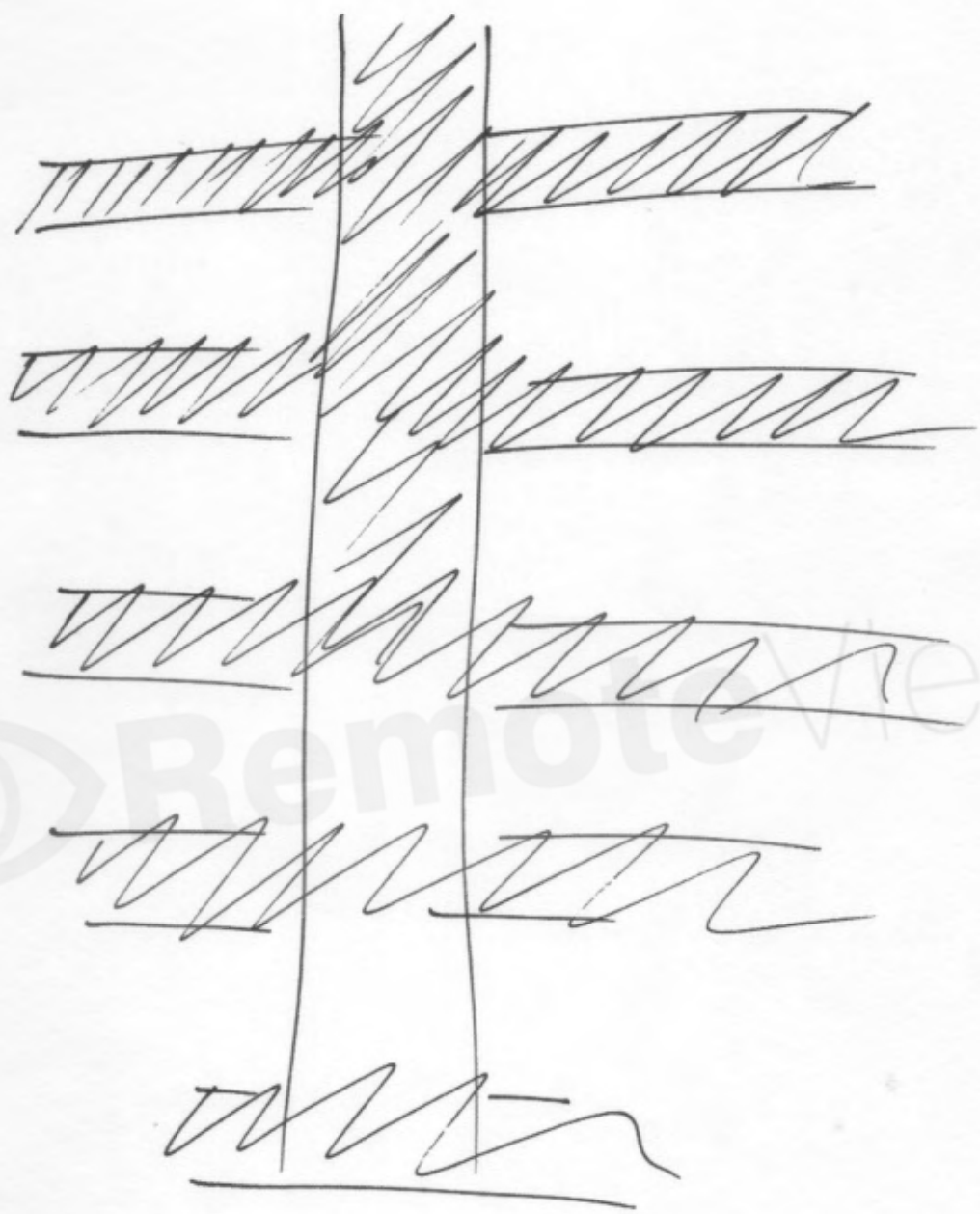

Busy
occupation
Researchful
Life.

Work-Like
Surrender.

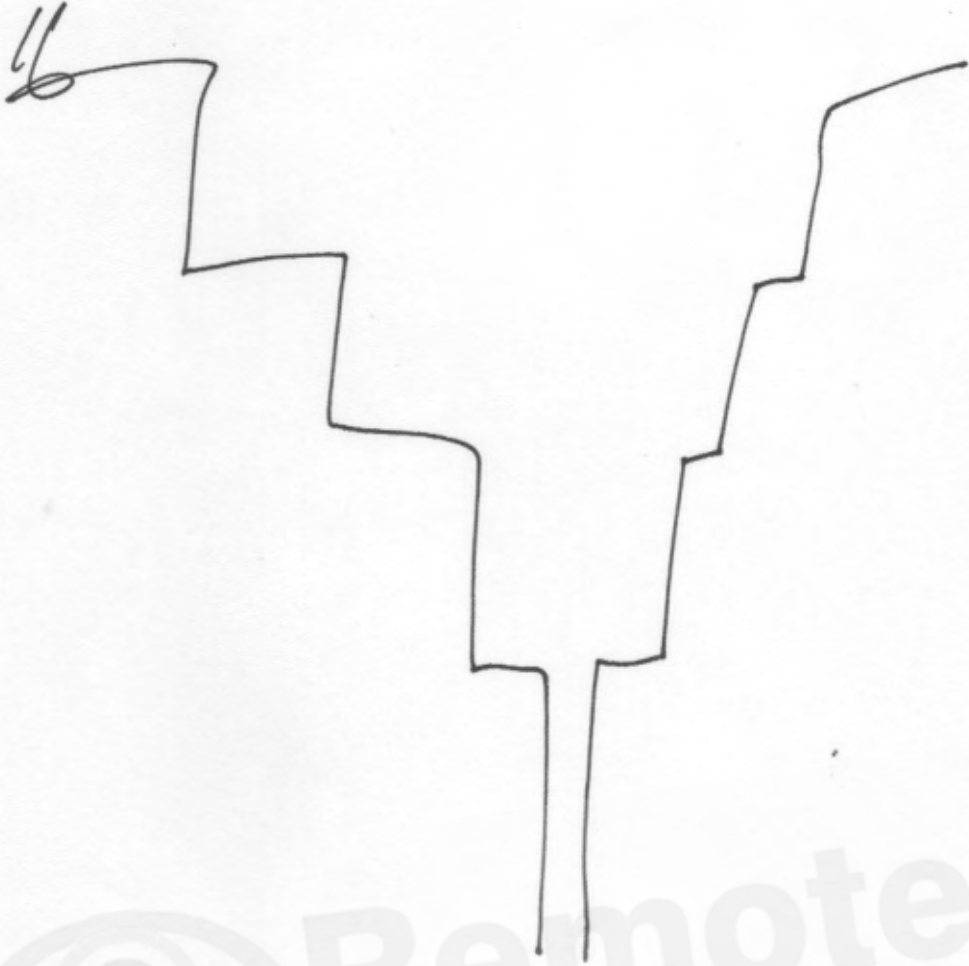

Downsweeps
beam
hidden
reactive

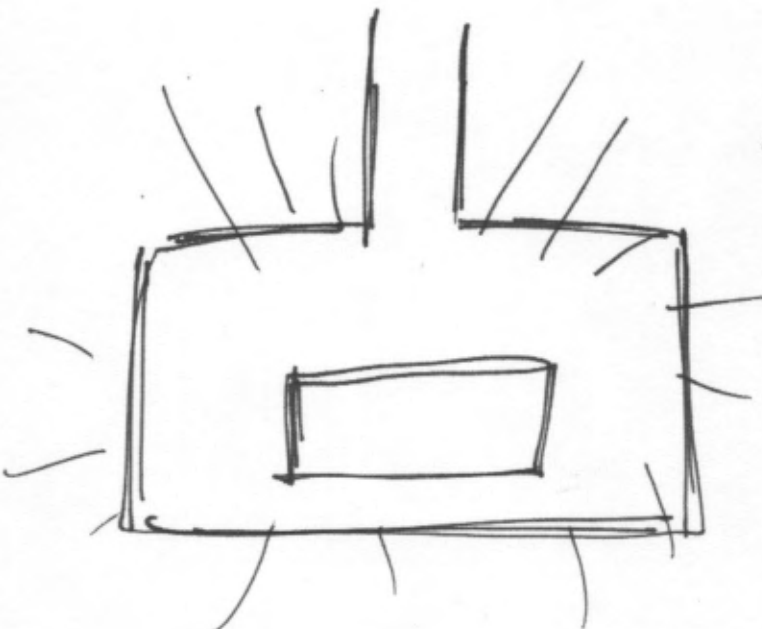

Energy
RADIATION.

Ac: WADOSH / KUSH, CIRAVHMY.

T1: RONGH / COOL. / HMER

T2: COOL.

V-Colors - BLACK / CRISPY. / EARTHLY.

Lm: DULL

Gov: LOW.

T3: ENERGY

O: SOME.

E.S. HUM. / VIBRATION.

Sub: ENERGETIC

D -

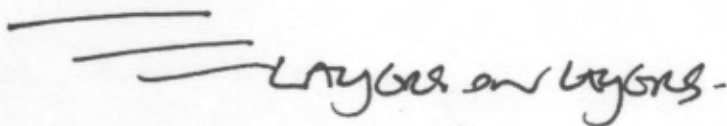

D: UP↑

MDSV: REALLY HEAVY, DENSE, THICK.
OPPRESSIVE WEIGHT FEEL.

ADL
CAUTION

Ac: A mix of ad/new.



Above ground structures.

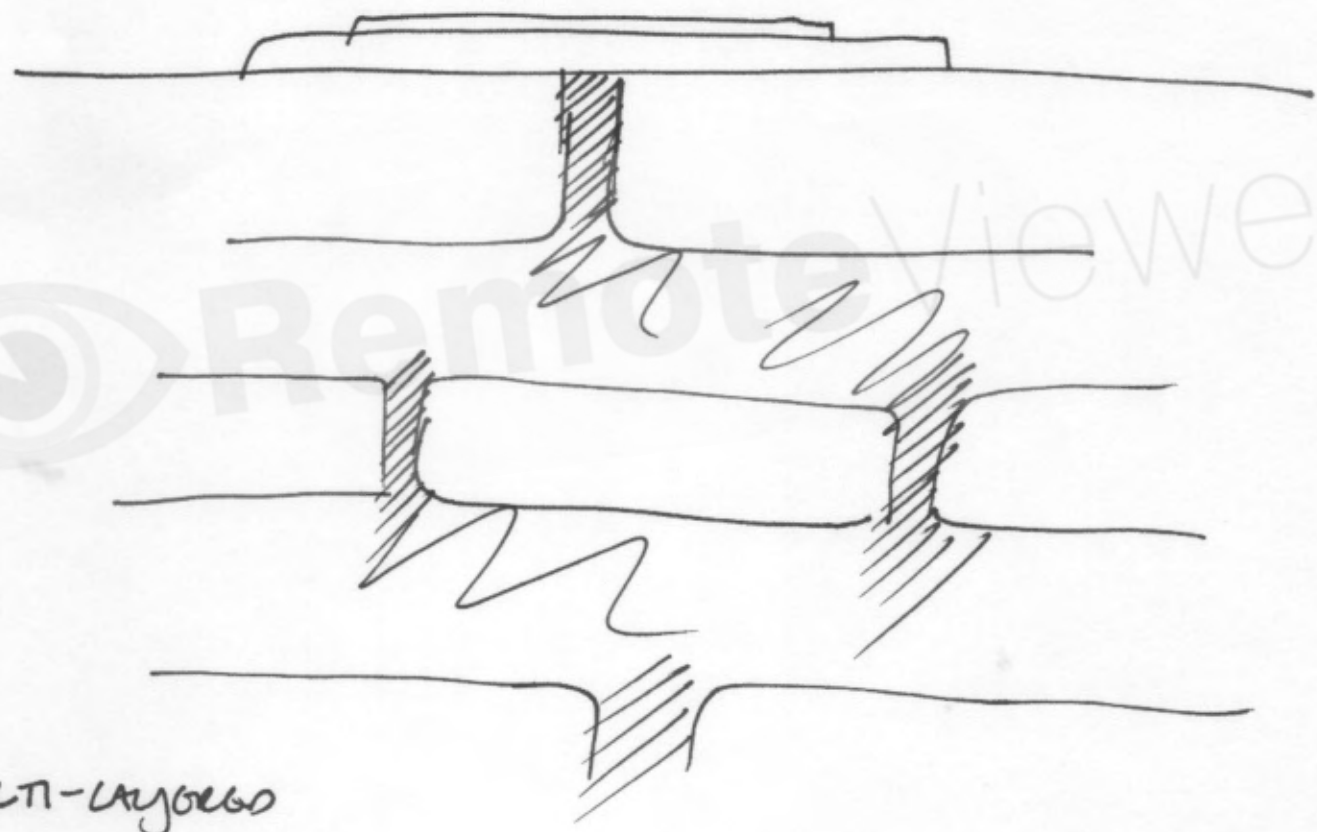

MULTI-LAYERS

below ground
sections/spaces.

LARGE SCALE.

DEEP.

TEN LEVELS?

ACL
ANT
HILL.

AL
WING.

S2 D Ae Ec T I Ae A/S

SECRET

STORGO
HIDDEN
WATCHED.
STUDIED
SKATED
KNOWLEDGE.

S4^k: THE TARGET LOCATION FEELS STRANGELY BOTH NATURAL AND ARTIFICIAL AS IF NATURAL THING ENHANCED/BUILT UPON.
↳ ALSO FEELS VERY OLD BUT ALSO NEWER.

A MIX OF NATURAL STONE SURFACES/WALLS + DEVELOPED-WORKED SPACES - FEELS DRILLED OR MINED-OUT.

↓
DEEP. WAY DOWN - UNDER.
LOCKED AWAY.

S2 D AC EC T I Max Nyls.

AGELESS
OR
TIMELESS

ANCIENT
OLD

S4 1/2: I FEEL THAT THERE IS AN OBJECT - THIS FEELS TRANSPORTED HERE - CARRIED FROM ANOTHER LOCATION - A SENSE OF 'SPOILS'.

A SECRETIVE PROJECT. FEELS LIKE SOLDIERS OR MILITARY SKILLED MEN ARE INVOLVED IN THIS ASPECT.

ARTIFACT.

UNKNOWN
ORIGIN

FEELS BOXED.

AD
CREATED.

FOR
TRANSPORT.

MOVED HERE.
IN THE PAST.

SZ D

AC

EC

T

I

Na

Nafs.



A SENSE OF SOMETHING CONTAINED - IN A CONTAINER.

THERE IS A FEELING OF ALIVE OR SENSITIVE ABOUT WITH THE OBJECT.

THE OBJECT GROWS WITH ENERGY. THIS RADIATES OUTWARDS BUT ALSO HAS A NOSE ASSOCIATED WITH IT.

PERIODICALLY THIS SEEMS TO CHANGE OR OSCILLATE.

I HAVE A SENSE THAT LIFE IN CLOSE PROXIMITY CAN COMMUNICATE WITH/OR USING THE OBJECT.

THIS FEELS ANCIENT, BUT ALSO VERY TECHNICAL AT THE SAME TIME.

IT FEELS CONTAINED AND OCCASIONALLY LET OUT OF THE BOX - STUDIED/USED.

THIS ALL FEELS ACQUIRED. ALMOST STOLEN?

Page: 9.

Stage: 4.

D.

S2 D AC EC T I AC Haps.

DESCRIBE THE SENSATION IN MAX DETAIL-ONLY:

Glowing

Energy-

Laid
Humming

DARKNESS?

INTERMITTENT.

S4¹/₂: A FEEL OF MEN/LIFE TRYING TO WORK-OUT-BACK
ENGINEER THE OBJECT. WAS KNOWN AS THE 'ACTIVIST'!

A FEEL THAT THE LIFE HOPS FOR KNOWLEDGE AND POWER
FROM THE OBJECT - WHICH THEY DO NOTHING.

SELF
DANGER.

THIS FEELS LIKE IT COULD BE PART MACHINE. I SENSE
MECHANIC PARTS - BUT ALSO A POWER SOURCE.
ALSO A FEELING OF INTELLIGENCE WITH THE
OBJECT.

AC:
ROBOT.

S2 D AE GC T L Vol No./

WHY HIDDEN?

GO INSIDE THE MIND OF A PRISONER LIKE INVOLVED OR/WAS THE STRIKE - DESCRIBE THOUGHTS:

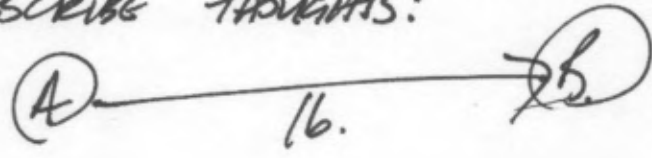

Goals.

Survival

Deconstruction.

power
Energy.

Drive
Warrior.

S4'E: SOMETHING ABOUT WAVES. INFORMATION ENCODED IN LIGHT OR RAYS OR SOMETHING.

LIFE HERE SEEMS BOTH MILITARY/SECURITY AND ALSO QUESTIONING/SCIENTIFIC.

As
PROB.

BUT ALSO A SENSE OF AWE AT THIS AND OF TOTAL LACK OF KNOWLEDGE AT FIRST.

S2 D

A T

EG

T

L

M

W/S

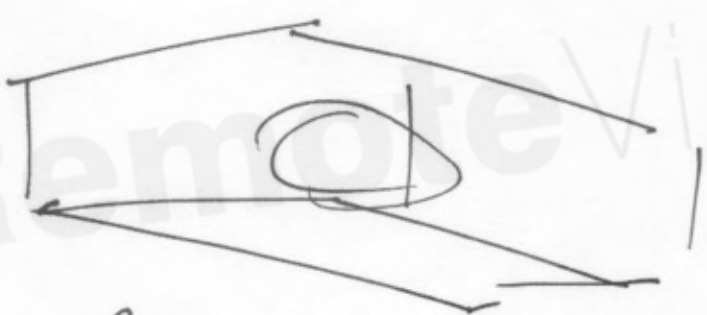
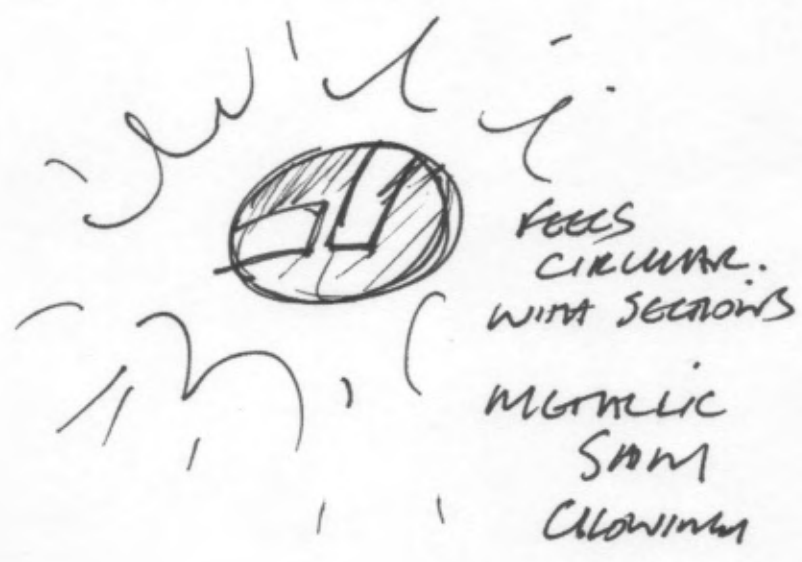

BUT ALSO BASE OR CONTAINER.

↓ DEEP DOWN

V-TACK WAUS, STRUCTURE.

BUT IT HUMS, GROWS, VIBRATES, THIS FEELS LIKE ITS VERY OLD - ANCIENT - SELF POWERED.

BUT ALSO FEELS LIKE ITS IN COMMUNICATION?

S2 D AEC EC T L Vol Mark

Communication.

WHO - WHERE?

DISTANCE.
ABOUT
AWAY.

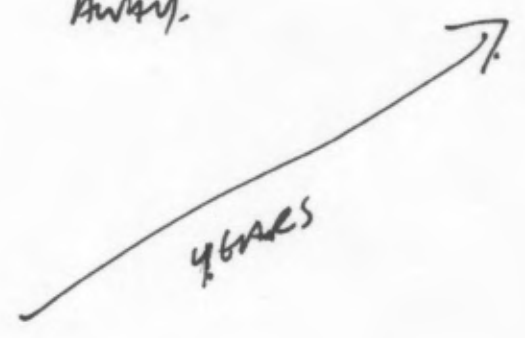

THE COMMUNICATION FEELS LIKE A VERY DISTANCE AWAY
LIGHT YEARS - BUT ALSO INSTANTANEOUS AT THE SAME
TIME. BUT IT ALSO FEELS - DAMPENED/MUFFLED
BY WHERE IT'S LOCATED?

HINDERED SOMEWHAT IN WHAT
IT CAN DO

ALL
TWOBBLED.

S4^{1/2}: INTENTIONALLY SUPPRESSED BY THE 'LOCAL' LIFE.

A NEXT LONG TERM STUDY PROJECT.

CONNECTED TO THE WORD 'ORIGIN'.

POSSIBLY LINKED TO HUMAN ORIGINS.

ARTIFICIAL. BUT ALIVE?

I HAVE NEVER FELT THIS TYPE OF DATA BEFORE.

THE SUBJECT FEELS LIKE AN ANIMAL TYPE INTELLIGENCE.

IT FEELS BOTH ALIVE/HAWKING AND ALSO MACHINE-LIKE.

IT MAKES NOISE, CLAWS, AND ALSO HAS AN ENERGY FIELD.

I SENSE THAT IT MOVED - BUT I DO NOT SENSE THIS NOW

- IT FEELS RESTRAINED OR CAPTURED IN SOME WAY.

IT FEELS LIKE ITS BEEN STUDIED FOR A LONG TIME.

AND HAS EITHER BEEN USED FOR OR IS A COMMUNICATION
DEVICE

I FEEL THIS CAN BE AND MAYBE IS LOOKED AT TO PROBE.

AC
SATELLITE
OR

BE WEAPONISED IN SOME WAY.

THERE IS A FEELING THAT IT COULD BE DESTRUCTIVE.

A STRONG FEEL THAT ITS:

CAGED.

CAGED.

ISOLATED.

STORING.

INTENTIONALLY.

END - 303pm. DAZ 😊

AC
HOSTAGE.

Page: 1
THURSDAY: 16.

Stage: 1

D.

5.5.17.

11.00am.

CRV.

BLIND

SOLO.

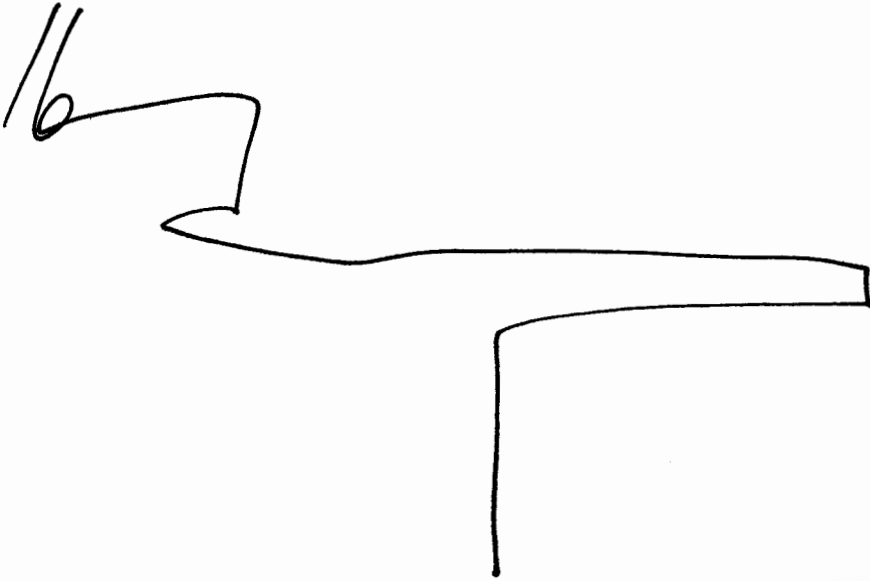

LAND.

INSTALL

SEWERAGE

DRAIN

MAINTENANCE

DEEP

TANK.

PROGRESS

STORAGE

EXPERIMENTAL.

~~AP~~
DEVICES.

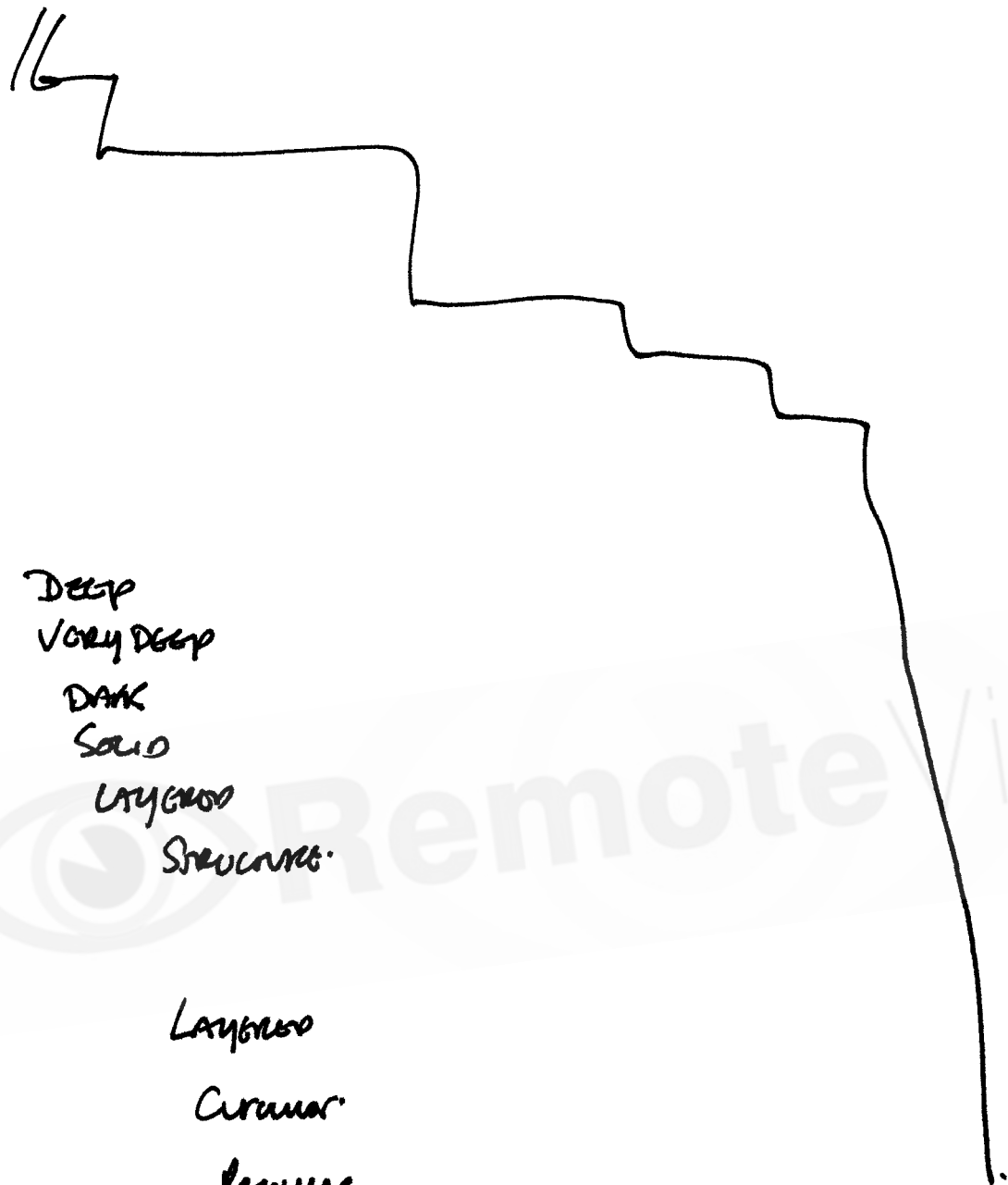

Deep
 Very Deep
 Dark
 Solid
 Layered
 Structures.

Layered
 Curved
 Layered
 Stages
 Annual
 Horizontal
 Zones
 Areas.
 Screening

AA
 Dark.

Page: 3.

Stage: 2.

D

Ai: Air Marina, Downiness

100
LIT
START.

T1: HARD, SOLID

T2: MILD

V - Colors: Colors, Neutral Colors

Lum: BRIGHT + DARK.

Con: LOW.

T3: AESTHETIC.

O: MUSTY / DRY.

E's: Hum.

Sub: Wonder.
Excitement
CUTTING EDGE.

4
RESEARCH.

D -

H:

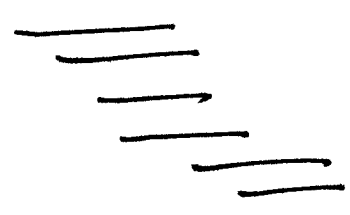

Separate / spaced / ungrouped

V. | Tall

D -

MDSU: THICK, HEAVY. Great, Industrial.

It: FEELS SECRET - HIDDEN AWAY.

16.

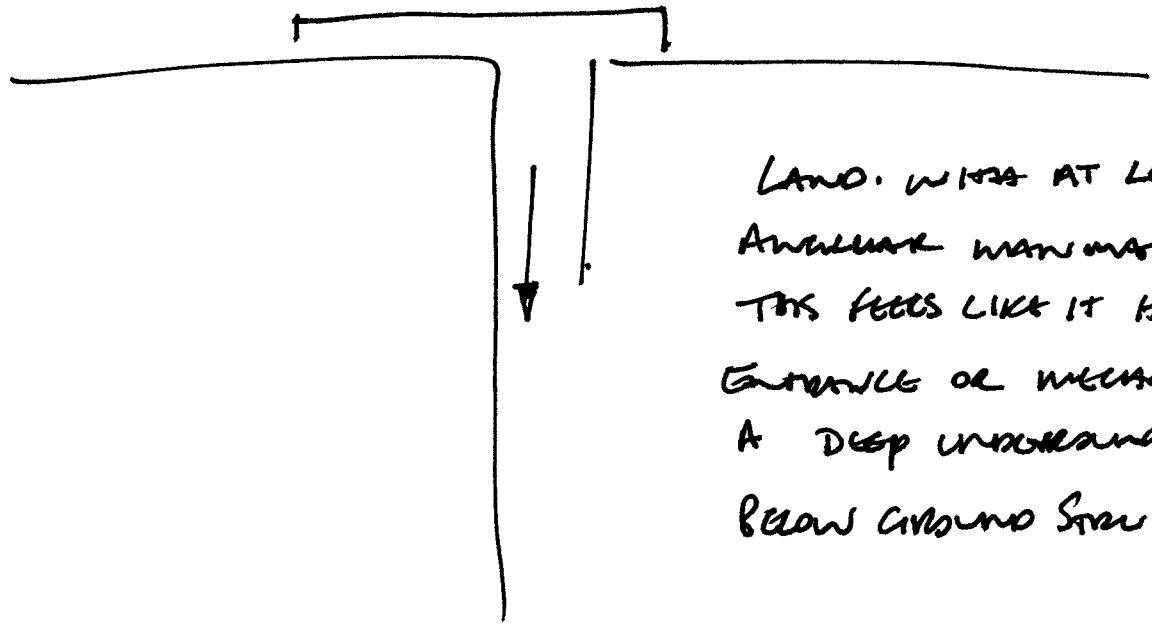

LAND. WITH AT LEAST ONE
 ANCHORED WALLING STRUCTURE
 THIS FEELS LIKE IT HIDES AN
 ENTRANCE OR MECHANISM INTO
 A DEEP UNDERGROUND STRUCTURE.
 BELOW GROUND STRUCTURE.

THIS FEELS LIKE A
 COMPLEX SENSITIVE -

BASED AROUND A CENTRAL WHEEL OR
 HUB WITH SPOKES OR ARMS
 THAT FEEL LIKE THEY ARE
 SPRINGS EQUALLY AS THEY

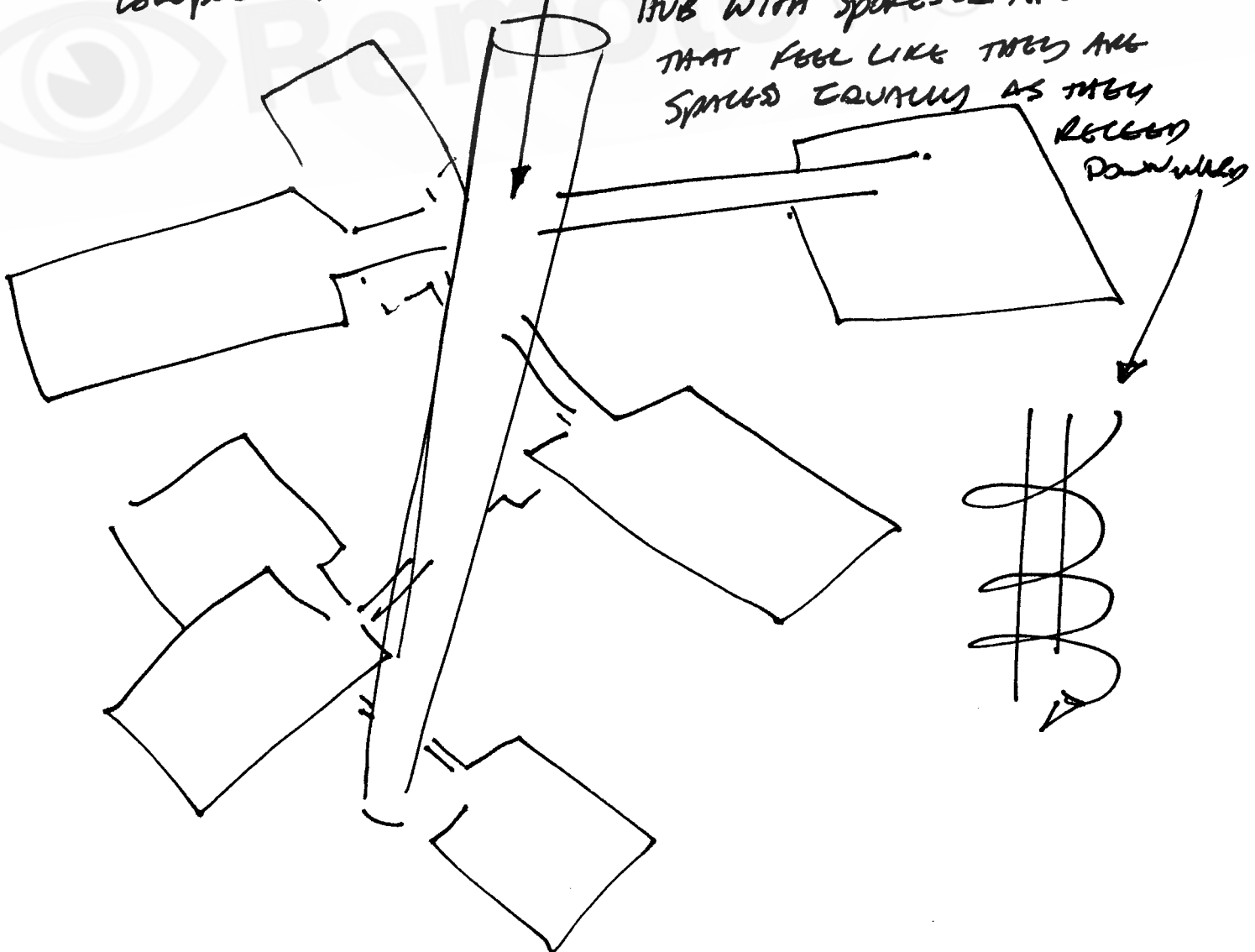

RECEIVED
 DOWNWARD

page: 41.

ABOVE VIEW

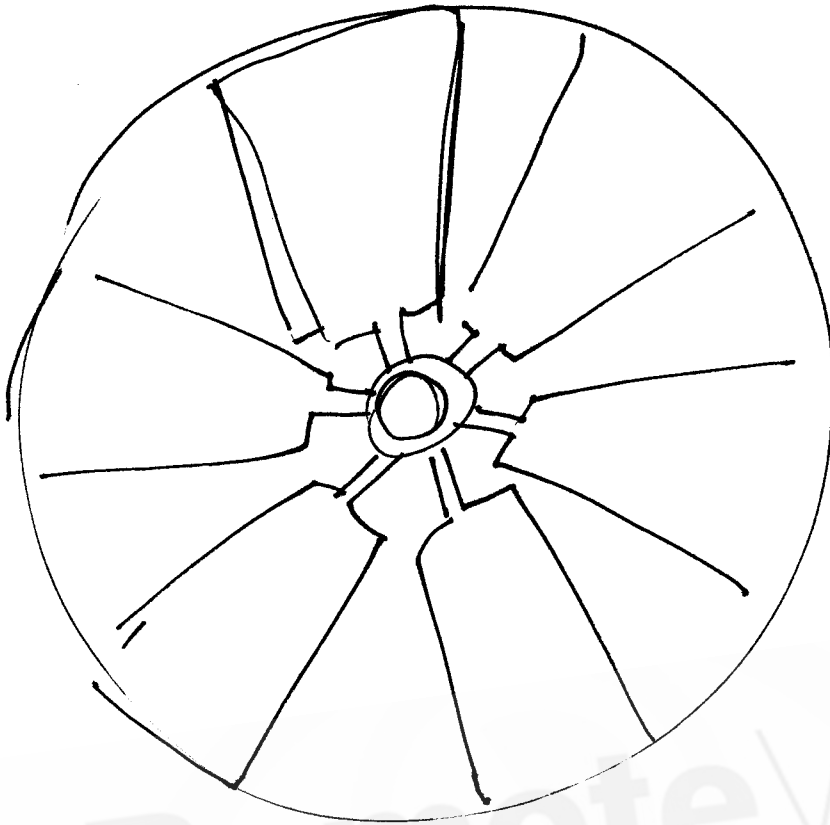

As
like
DNA
strand.

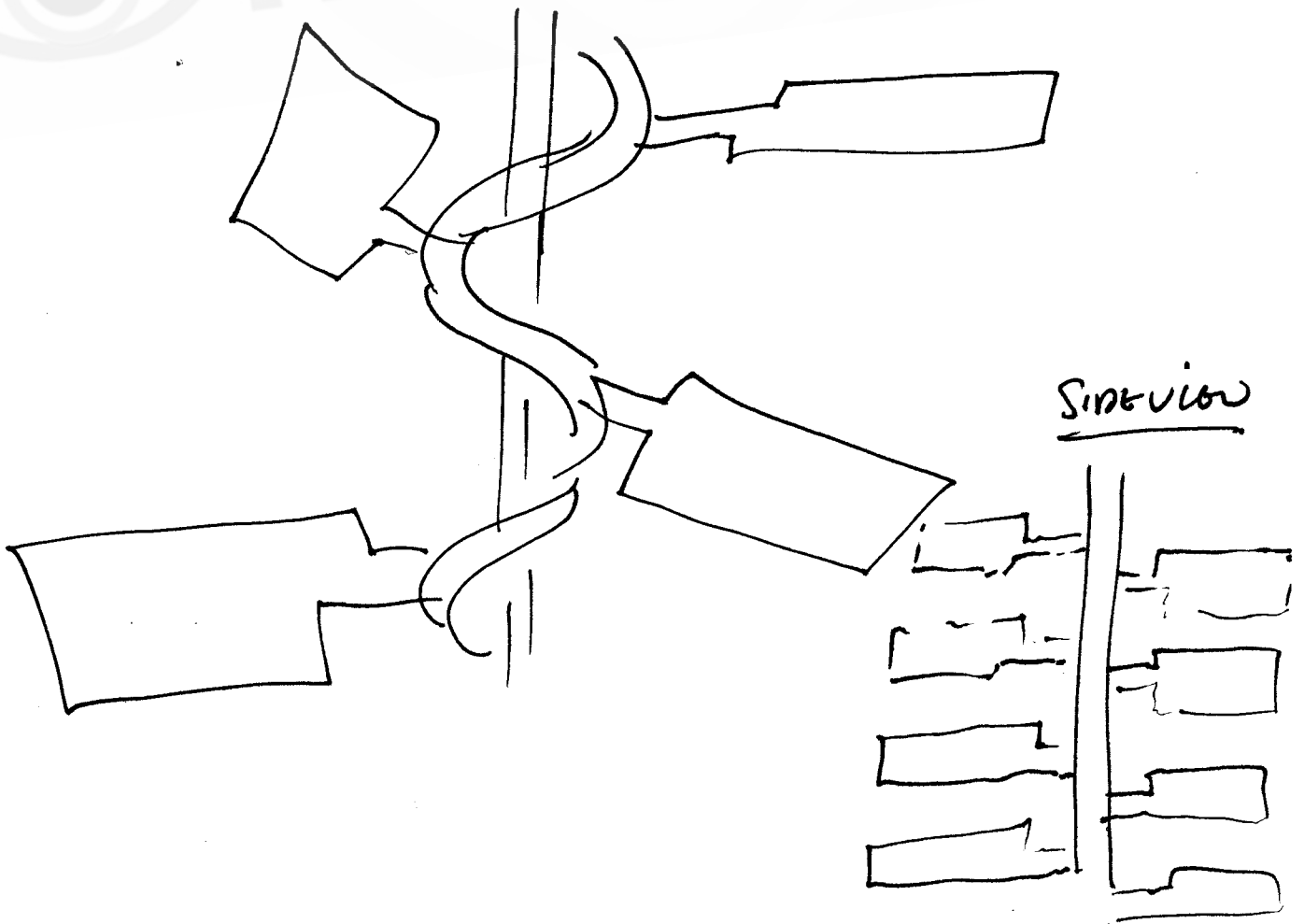

Side view

SZ D At GC I I NL N/S.

MOVE FROM THE TOP DOWNWARDS THROUGH THE STRUCTURE - DESCRIBE IN FULL DETAIL - ONLY:

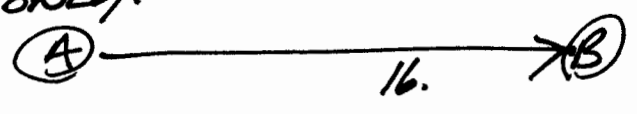

1.

NEW

. BUSY.
ALL WORK
UNIFORMED.

SECURITY.

TRAINED
DEADLY
SERIOUS.

ELECTRONIC.

SL 1/2: OK. THIS FEELS LIKE AN INTERFACE WITHIN A STRUCTURE. IT LOOKS/FEELS VERY CLEAN MODERN - NOT UNLIKE AN AIRPORT.

THERE ARE SCANNERS - FULL BODY - ALSO OTHER ELECTRONIC LOOKING DEVICES.

CORDIAL BUT OPPRESSIVE FEEL - ALL BUSINESS.

ALL UNIFORMED.
HEAVY WEAR BUILT
UNIFORMED (GREGG).
UNIFORMS.

Next

MOVEMENT
DOWNWARDS.

BOUNCE

GRAY.
SHINY
WALLS.

SPEAKERS.

MUSIC.

S4 1/2: THIS FEELS LIKE A VERY LARGE ROOM SIZED LIFT THAT
MOVES DOWNWARDS - WOODEN, COMFORTABLE, MODERN.
FEELS LIKE THERE IS MUCH LONGER TIME THAN IN A
LIFT GOING BETWEEN FLOORS IN A BUILDING.

GRAY
SHINY
SILVER.
BRIGHT
LIGHTS.

NO ONE IS
SPEAKING.

LIKE A
TUBE
TRAIN.

PASSENGER
TRANSPORT.

AIR FEELS
DIFFERENT IN
HERE.

SZ D AC EC T E AOL NLS.

1st STOP.

WALL IT.

LOW
AVAIL.

COLLABOR.

NEW

SECURITY

S4 1/2: THIS FEELS LIKE ITS ADMINISTRATION, CHECK-IN, LOTS OF STANDARD ROOMS, SPACES, EATING, WASHING, TOILETS, CHANGING, ACTIVITIES. COMMUNICATIONS.

VERY MUCH LIKE A MODERN OFFICE BUILDING BUT SECURITY CONCERNS - VERY SERIOUS SECURITY.

NOTHING LEAVES OR GETS-IN WITHOUT SCRUTINY.

LOTS OF PEOPLE HERE - WALK/PARKING.

WALK WALK THOUGH.

S2 D AG EG T E HCL HCL/S

THERE ARE OTHER PARTS TO THIS STRUCTURE:
SOME ARE SCIENTIFIC SOME ENGINEERING.

BIOLOGY

- GENOMES / GENOTYPES / DNA.
- MUTATIONS.
- DISEASES -
- COMPLICATIONS

LOTS OF EXPERIMENTATION.

VERY CLEAN ENVIRONMENTS, LOTS OF EQUIPMENT
VERY HIGH-TECH.

S4^{1/2}: IT FEELS LIKE THEY ARE LOOKING AT DNA - SPLICING,
SEQUENCING - DEBUNKING OF SOMETHING.
LONG TERM - MANY YEARS.

VIROLOGY

- VIRUSES OR BACTERIA.
- I SEE COMPUTER STORAGE OF THESE.
- EXPERIMENTATION.

S4^{1/2}: LIKE A LONG CODE BEING UNRECORDED.

LOTS OF COMPLEX THEORIES - DIAGRAMS - A COMPLEX LONG TERM
PROBLEM?

S4^{1/2}: TEAMS - WORK ON THESE PROJECTS - FREELY SEPARATED IN
ORGANISATIONAL STRUCTURE AND IN SOCIAL WAYS -

LABORATORIES.

HOW
NEED TO
KNOW.

SR D

AC

EC

T

I

AL

Vol/s

Energy.

SHIELDED - DEEPDOWN - AREAS.

Complex, multi structural meetings.

THIS FEEL LIKE BOTH A CREATION AND BACK ENGINEERING EFFORT.

MULTIPLE DEVICES / ENERGY PRODUCTION METHODS BEING EXPERIMENTED WITH.

VERY EXOTIC

LARGE + SMALL.

- SMALLER TEAM, MORE MEN. OLDER MEN.
- LOTS OF TESTING, VERY PHYSICAL / MENTAL.

Weaponry.

I FEEL THAT THERE IS AN AREA RESERVED FOR RESEARCH / EXPERIMENTATION INTO THIS. THIS ALSO FEELS LIKE IT INTERSECTS WITH OTHER AREAS -

- SCIENCE - ENERGY.

I SEE MEN WORKING ON SOMETHING THAT PULSES A BEAM OF INTENSE LIGHT (PLUS SOMETHING ELSE) OVER A DISTANCE TO A TARGET. - MATTER OR MATTER SCATTERING / DISPERSING?

AL
MELA
51.

S2 D Ae GC T F Ae Ae/s.

Movement.

HIGH
TECH.

STRUCTURES

CRAFT
VEHICLES

Aerodynamic

S4 1/2: THESE FEELS LIKE A SECTIONED HANGAR TYPE AREA WHERE MOTION/TRAVEL IS BEING EXPLORED

SOME NEW DEVELOPMENTS, SOME BACK ENGINEERED FROM RECOVERED TECH.

VERY SECRET - WALLS. CLOSE TEAM.

EXPERIMENTAL

FLYING
STRUCTURES.

SIX.

S4 1/2: SOME OF THESE CRAFT LOOK/FEEL DISASSEMBLED IN PART - SHOWING SKELETONAL PARTS.

SILO-LIKE - VERTICAL LAUNCH TUBES. FOR SOME OF THESE - A FEW (ONE OR TWO) NEED TO BE MANUALLY TRANSPORTED - TO BE TESTED. - TESTED OUTSIDE?!

Page: 11

Stage: 4.

D.

52 D AGE EC T F HPL Vol/s

DESCRIBE IN DETAIL ONE OF THESE PROJECTS/CRAFT BEING TESTED.

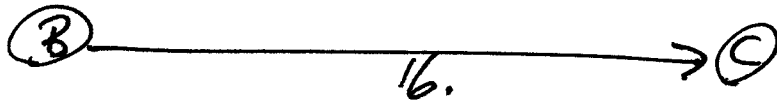

OPASUG.
PERCUSSION

CRANIAL
BRIGHT
OSCILLATING
RAINBOW
GRAPE.

S4/2: THE SKIN OF THE CRAFT GLOWS - FROM INSIDE/OUT.
A HUM-ELECTRIC.

A FEELING OF COMPRESSED WEIGHT/AIR WITHIN THE
VICINITY OF THE CRAFT.

IT LEVITATES

UFO SAMPLE?

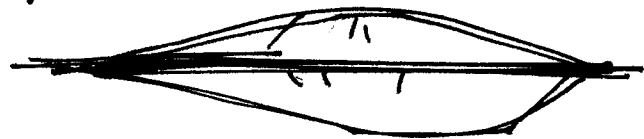

STEALTHY.

BENDS TIME + LIGHT.

HOLOGRAPHIC.

FEELS FULL OF ENERGY - WOUND UP - WANTS TO JUST ZIP AWAY?

page: 12.

Stage: 4

D

SZ D AC EC T I AC AC/S

MEASUREMENTS BEING MADE - LOTS OF DATA RECORDED ON COMPUTERS. GRAPHS, NUMBERS, RATIOS,

FEELS ANGULAR.

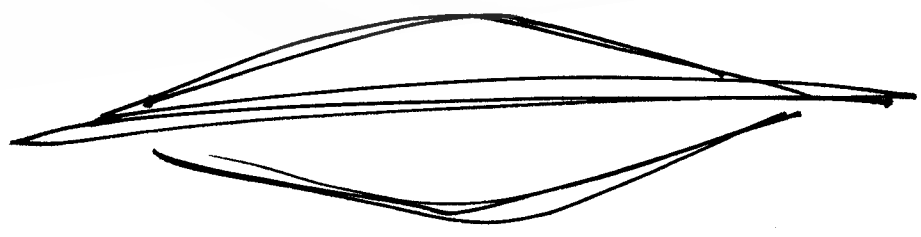
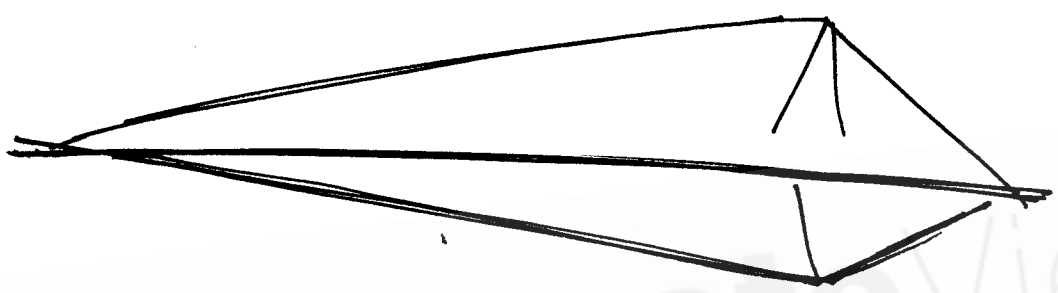

RemoteViewed

page: 15.

THE THREAT FEELS LIKE A REMOTE, HIDDEN, DISGUISED STRUCTURE.

OVERLOOKED BUT MAINLY UNDERGROUND.

BUILT IN/ON/AROUND EXISTING CAVE - THEN EXPANDED.

THIS FEELS LIKE A DESIGN/RESEARCH FACILITY

BOTH MILITARY + SCIENTIFIC - VERY SECURE, SECURITY CONCERNS.

WALLS LABELED (10).

VERY DEEP DOWN.

VERY ARCHITECT.

VERY SECRETIVE

HAS RETRIEVAL TEAMS - THAT PROVIDE ARTIFACTS - THAT ARE CAPTURED, EXAMINED, BACK ENGINEERED.

HUNDREDS OF PEOPLE WORK/LIVE HERE FOR DECADERS OF TIME.

COMPLEX FACILITY - LIVING AREA,

IT FEELS LIKE IT HAS PROBABLE RUNWAYS - EITHER ON OR CLOSE BY -

THIS IS FOR TESTING + TRANSPORT.

REMOTE - OBJECT-LIKE LOCATION

NOT JUST ~~TECH~~ TECH/EXOTIC SCIENCE - BUT ALSO

BIOLOGY, EXPLORED HERE.

BEYOND EXOTIC + CURIOUS GOING AT TIMES.

WAY OUT IN LEFT FIELD - STUDIES - RESEARCH.

Page: 14.

STORMS / LIBRARY / UNCLT.

ARTISTS SOLGD.

BIOLOGICAL STUDIES - SAMPLES.

DATA SCIENCE.

EXPERIMENTAL REJECTS.

MULTIPLE LEVELS OF CHECKING / SECURITY AT THE THREAT -
IT'S VERY SERIOUS - OPPRESSIVE. EVEN. - SCARY.

CODE WORDS. USED.

BLUE ORCHID

— SWORD

S4 1/2: A FEEL THAT THE BIOLOGY IS NOT JUST HUMAN
BUT ANIMAL AND PROBABLY EXOBIOLOGY.
EXAMPLES - SAMPLES - STORGO.

Abc
S4.

12.55
END



DAR.