



Steve Fossett Disappearance

October 2008

Remote Viewing the Steve Fossett Disappearance

This target was tasked to The Aurora Group (<http://www.the-aurora-group.com>) by one of its members on or around 4th September 2007. Aurora at this time produced a stream of constant targets and projects and this was just another one of these. All Remote viewers were BLIND to the target and only had the coordinate (random number) to work with.

A separate remote viewer and member of Aurora (Marv) was asked to look at the RV sessions and create an analysis document of the data - this is also included herein.

Now that Feedback and a conclusion can be found to this event we feel that we can share with you the remote viewing data in full and as the days go by and we all learn more about what probably happened the data can be checked for overall accuracy.

The remote viewing data has been enclosed here in its raw format and includes differing methodologies in play including (CRV, TRV, TDS, & freestyle).

First we present the tasking document, then the BLIND analysis by Marv, then the viewer sessions one by one.

AURORA TARGET 7222 - 8444

DESCRIBE THE LOCATION OF AVIATOR **STEVE FOSSETTS PLANE**
AND CIRCUMSTANCES SURROUNDING HIS **DISAPEARANCE**

http://www.usatoday.com/news/nation/2007-09-04-fossett_N.htm



Lingering impressions approximately one hour after reading all sessions:

Troubled male life form with worries on mind
Something having fallen from above
Desert area

Further comparison of data

(increased size of words indicates degree of data agreement)

Physicals

Buried in sand
Desert area
Remote
Gully
Hills
Large raised mound / hill
Massive structure
Near sea or expanse of liquid

Objects

Coins
Heavy
Mechanical, metallic
Flying vehicle
Vehicle
Cylindrical
Curved

Lifeforms

Distant traveller
Foreign
Male
Alone
Focussed, driven
Too focussed on work
Headstrong
Tourist
Unhappy

Concepts

You will not find
Alien to this planet
Legend
Related to star
Distant past
Others watching on
Death through suffocation
Accident
After an event
Life after death

Movement

Windy
Swirling
Vibrating
Undulating
From above
Falling

Emotions

Abandoned
Anxiety
Nervous
Betrayed

SUMMARY

Based on the data comparison above the target site appears to be an isolated location comprising near-desert like conditions and featuring an extremely large natural structure set amidst undulating hills and in close proximity to a large expanse of water.

Central male life-form engaged upon some task involving solo travel to or from a distant location. It is suspected that this location is extra-terrestrial or at least from somewhere high above the planet's surface. Though initially enthusiastic the life form soon became troubled and not at all happy about the task that he was been required to do. Somehow he has been betrayed by others and to a certain extent abandoned.

Connected to the life form is a metallic object or vehicle, most probably the method of his conveyance. The movement of this object is swift though it is not necessarily propelled in the conventional sense. Associated movements included a swirling, undulating effect.

The task/journey lead to the lifeform's eventual death through a form of suffocation. The event was monitored by others from afar, others regarded with a certain degree of animosity by the life form in question.

At present the remains of this life form and/or his vehicle remain unlocated at some remote place on the planet.

Despite the obvious extra-terrestrial overtones there is a definite human feel to this target; it is highly probable that the life-form involved is a human being.

A Note on Analysis Procedure.

Analysis took part in 3 stages:

- 1) All sessions read, no notes taken, general impression/memory noted down one hour later.
- 2) Sessions reviewed and dominant concepts / data chunks taken down. The more a certain `chunk` of data cropped up in each session, the more I increased its font size.
- 3) Written summary attempted based on results of stage 2.

7222-8444

v. up across
loop top
vibrating

7222-8444

roll down
loop
soft

S2 soft
hard
wet
sticky
liquid
warm
green
white
yellow
black
menthol
paint thinner
Salty
metallic
washing
cutting

smell

rolling
spherical
AZ-bruizen
above
big
round
spinning
up
sideways
looping

AZ-happy

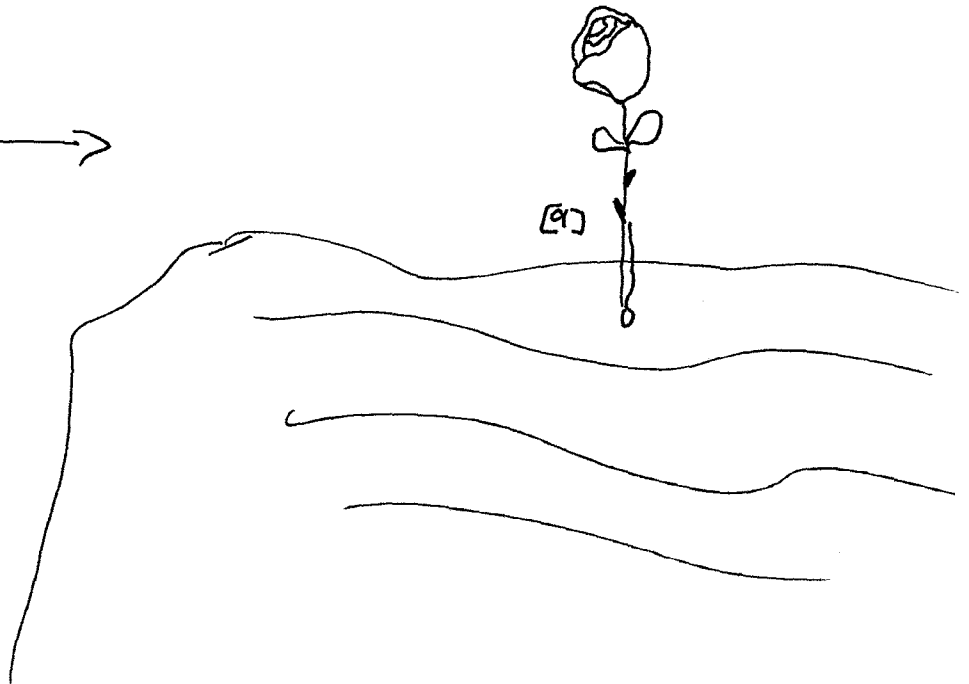
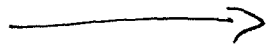
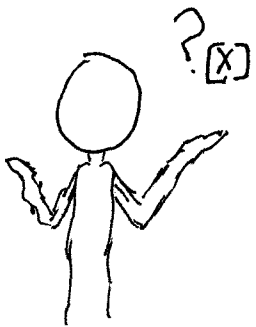

[X]
WSP

↙ across v. up
Salt

SZ

hard
metallic
murky
soft
wet
sweet
earthy
pungent
yellow
green
brown
black
clam
bitter
earthy
rusty
churning
warm

rolling
big
upright
solid
heavy
mechanical
above
· AC- shore line
spherical
indented

AE · silly

53
(X)

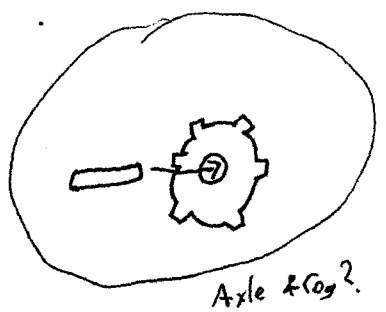
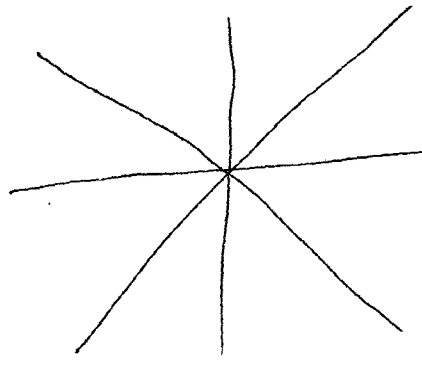

Axle & Cog?

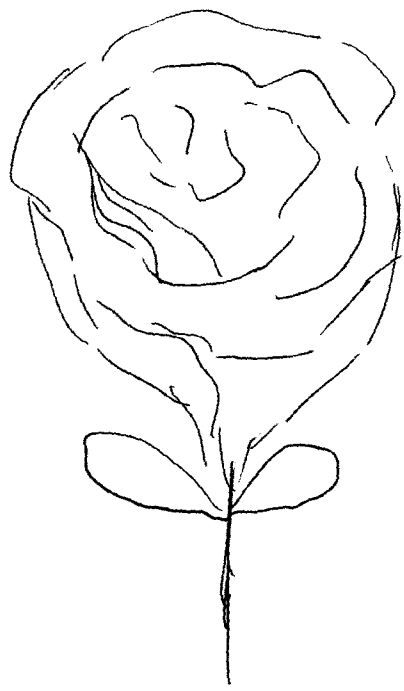
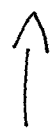

Flower
Represents
Symbolic

relates
to
this
man



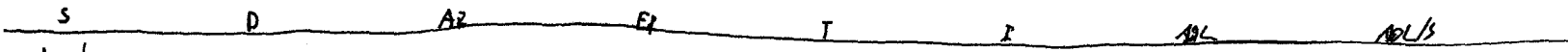

hand

fast
 big
 splayed out
 under
 dimensions 9x6x10?
 above

AGL - far out
 near ocean
 AGL - desert clouds

vulcan
 mauve
 blue
 sparkling

brown
 gritty

hollow

AE-nervous

excited
 agitated
 nervous
 sleepless
 anxious
 weary

sleepy
 ornery

'traveler far away'

SL1/2 lots to come
 SL4/2 shielded from rays of sun
 SL1/2 messenger ^{from} ~~to~~ God

dig
d:down
dig
soft

G1
LBR

G2
green
yellow
brown
smooth
fine dirt dirt
brown
yellow
green
grey
blue
cham
stony
salty
warm
glutinous
rushing

oval
spherical

big

not appropriate?

oval
high

around

in

shallow

not wandering the desert plains

round

South Africa

heavy

AF-curious

53
[a]

7

star

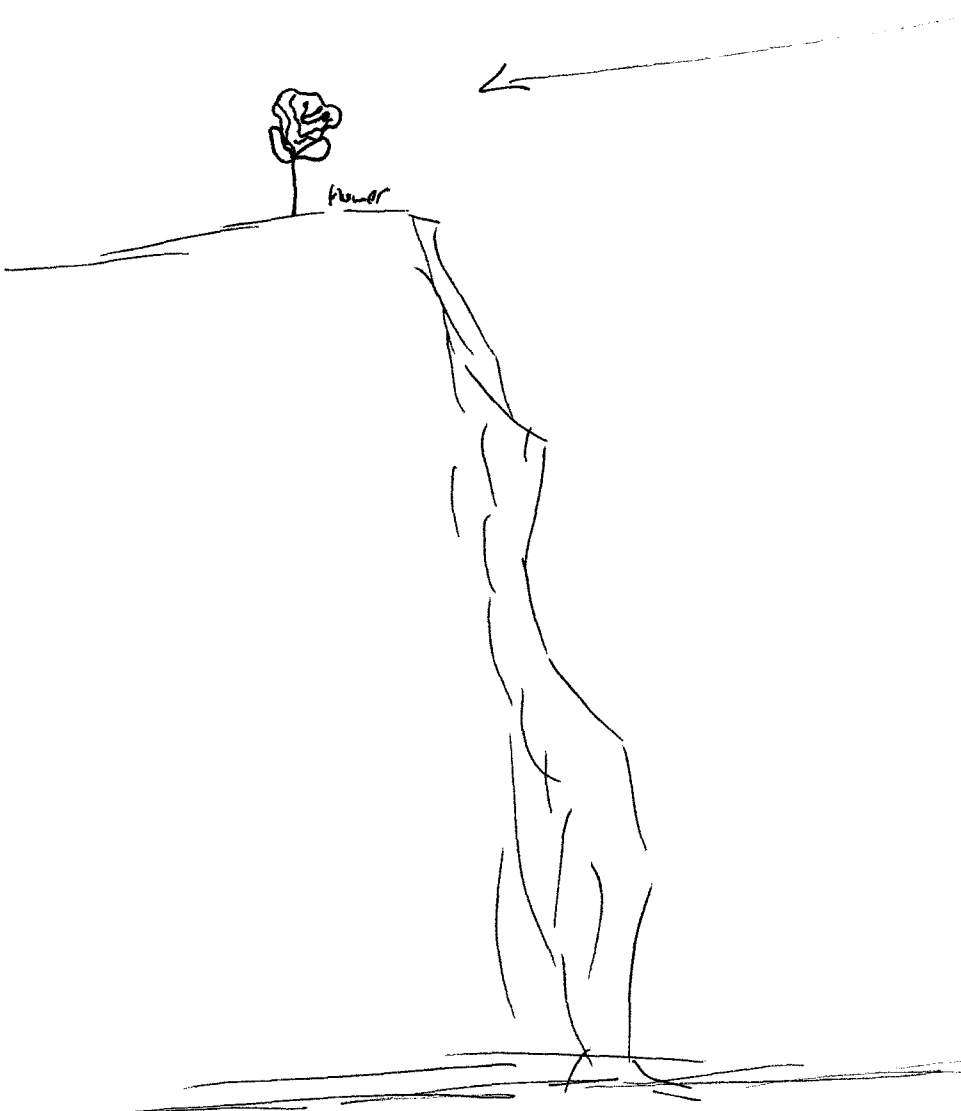

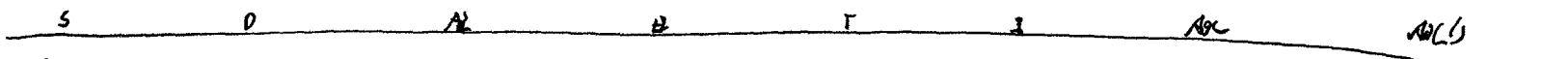

Orange
Blowing

spherical

Yellow
red
blue

pink

solid
square
round
oblong

peach
blue
brown
white

round
tiny

'bi-focals'

AE - passionate

hurry

love

consideration

.

.

.

miser

continually oppressed

stars

open

land

little construction

AQL - the star flower

S D AL EL T L ACS Ad

[Significance of Star A Flower]

slightly made for each other

mystery of time
from another planet
distinct to nature
reproduces differently
left over from the old age
patterns of life forms not like those here

(information most desired by task or client
related to his target)

buried in the sand (bone)?
wrapped in leather

coins

internal w/ undergrowth
you will not find

happy days

legend

End

Target: 7222-8444

Viewer: Daz

Method: CRV (loose)
Double blind

Beginning of stage I during cooldown had the immediate impressions of a missing life – before I even started. Thought this had AOL'd me

Land:

Seems to be important in both sessions.

Feels grainy in places very earthy, warm and dry, almost desolate/parched/desert like – very earthy and natural not allot of manmade land/roads.

Very natural undeveloped place.

Life:

Involved in an activity which involved movement in both sessions. In session I the movement felt like a man made structure (vehicle). I felt the life was in a purposely arranged space in the man made structure. Session I showed the life alone and dead in a remote natural location.

Session2:

Shows life in an erratic activity/movement.

Shows a life, in a remote place, feels alone and feels like a natural setting, dry/parched earthy. Sporadic vegetation, yellows and browns.

The attention is focussed on this life.

A farm/house is the closest structure – feels over the hill – behind and to the right of the life. Feels remote from the life.

A feel the backdrop for the location are rolling or softly undulating hills – I see hills – it all feels peaceful and natural.

Internal suffocation might be the cause of death? (I dont know what internal part of this means – either you suffocate or not?)

Data suggests some kind of incarceration possibly contained maybe for a time before death.

Final images were of a low outcrop of rock with a natural well or space underneath.

Cool/shaded, earthy, rocky.

Cavelike or a little 'hollow'. Maybe something pink in the earth?

Mid way thru stage2 had deep impressions/AOL's of missing Madeline – hope it's not ☹

I: 20 MIN CLASSICAL MUSIC MEDITATION.

FEEL COOL.

4.15pm
CRUISE.

7198-6363



a. life

people
busy
nutters
a central theme
character.

b. movement.

activity
intense.
feelings
promotional
heightened.

AsC
↑
focal
point
Attention.

7198-6363

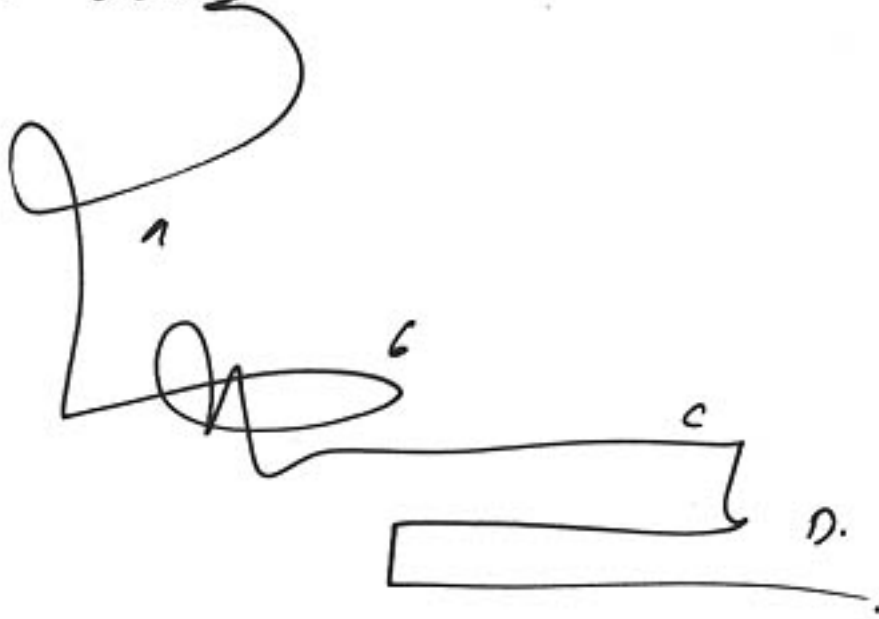

- a. life.
- b. warmth
- c. Structure
- d. Structure/land.

S2

warm
with

Bibby, Dry, Dusty, gray.

Sparse.

Hilly, Hills. Deep hills.

Dry, Dusky. Baked. earth.

moment Dawn.

Aol
Kionipad

7198-6363



A: Down, Across, Down, Across.
Soft.

B: Hard

Warm, dry, brown, Soft.

Sporadic vegetation - hard rock - Sharp.

Warm to touch.

Ac
Hillside.

A: Cuckats. Distant Dog barking. wind.

T1: Rough, dry, Splintery, textured - weathered.

T2: Warm

V- colors - brown - red - yellow ochre.

Luz - Bright

Ear - high.

T3: ~~Salt~~ Salty, butter, & dry, earthy.

⊙: fresh, pollen. - a flower.

ES: Wind, noise.

Sub: Why? watching, outcome - distant - argv. - pain! reasoning!

the
fields

D . A 

V 

D

MD SV: THICK open, Spaces - indenting

At: KILLS rembr - calm/warm.

MOVE ABOVE THE TARGET LOCATION TO THE BEST POSITION -
TO SKETCH AND DESCRIBE IN DETAIL.

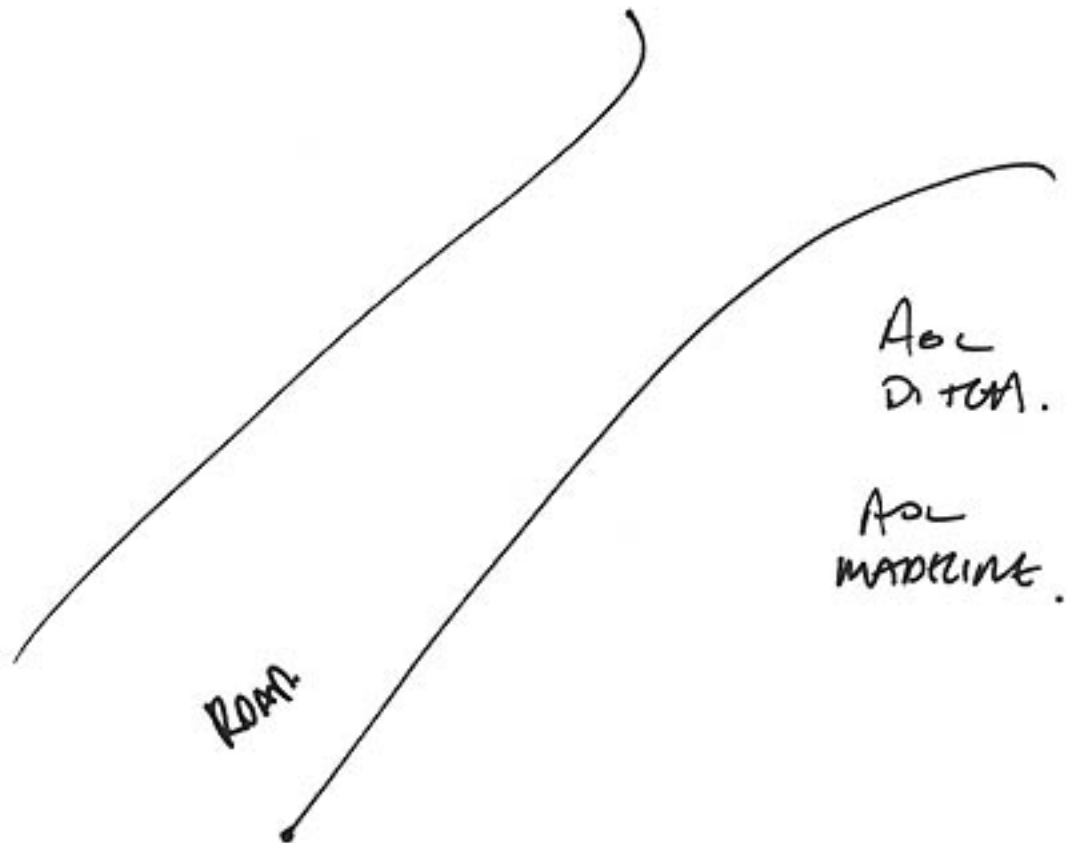
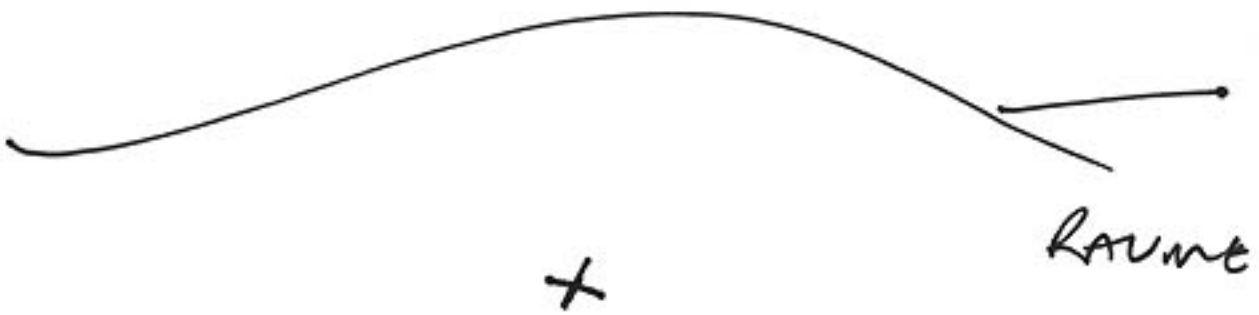
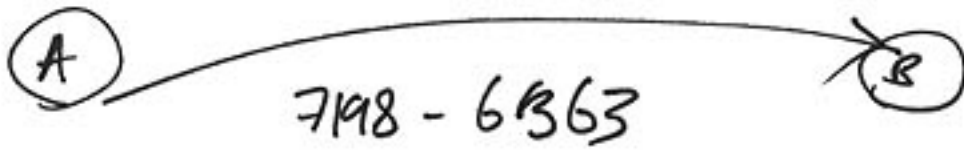

MOVE TO + SKETCH THE RELEVANT THEMES LIT FORM

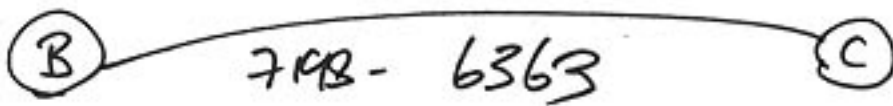

focus
 Angry
 Solitude
 distress

why?

A presence . overwatching - a Shepherd?
 Unseen.

APL
 like
 JESUS.

Panic

ATTACK

DISTRESS.

Anger.

page: 6.

Stage 3

off.

MOVE TO TARGETS INTENT/PURPOSE + DESCRIBE WHATS THEY NEED.

SOUTH OF TOWN.

DEPRESSION.

WIDE.

EXPANSE.

ORIGINAL - ORIGINALITY.

FATALITY.

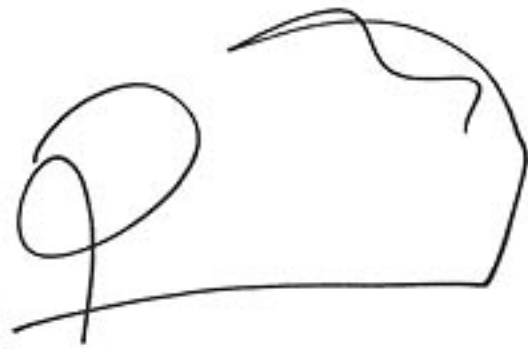

LIFE
CONTAINED

CONTAINED.

INTERNAL SUPPRESSION.

RELEASE

END

DISSENT UPWARDS.

DESCRIBE THE LIFE OF INTEREST IN DETAIL



open, expressive.

Fortitude.

A zest for life.

Adventurous.

Keen.

Dominant.



AN OVERLAPPING
OUTCROP

CAVE / HOLLOW

DARK / COULDER. DRY - STONY.

Something about pink?

APL
BEEP

TOO MUCH APL. OF LITTLE GIRL MADDY. END :)

PI - None T-M
CF: M

7 Sept 07
22:00

7222-8444



A: fast, looping, high.
B: motion
C: edge

S2

hard
solid
flat
grey
red parts
gleam
tall
thin
yellow

aol: trees

smells: sickly chemical
Tastes: acid
temps: wet/cool
sounds: bird-calls (?)
rustling.

high pitched
squeaks.



like a fish
fillet or a
feather shape
nbs sections: (act. wing)

(hot break)
(noise)

fish
aol: bone



metallic
round
hollow
cylindrical
manmade object
white
smooth

[move up close to
the focus of the
target]

aol: machine

53

2

[Rise above target to 30'
look down at flow +
do cube]

person



lifeline

tangled up.

Act: man lying
on front

(Too much asl
breaks)

Volume .



asleep?
injured?
sick?
male?
drunk?
peaceful.

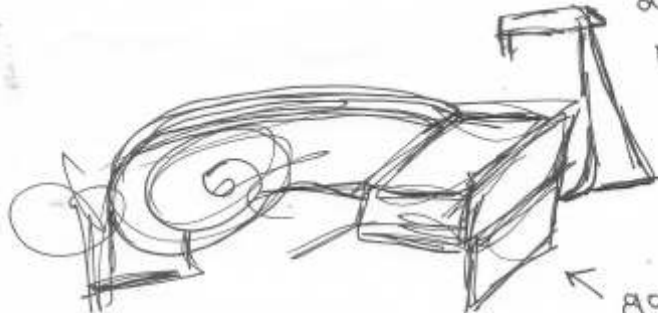

← goodness
knows what
this is
RV doodle? 😊

SZ D AI EI Tan Intan AOL HO/S



wings
twisted
metal

metal

target

object
life
maybe machine
quietness

aftermath!

'calm after storm'

accident → (AOL)
result of something

paint

small
container

sack

vehicle
travel

alone!

not happy at
this time

trees

'life after
death'
'whose do I go now?'

green
brown
heat
smoke

END

Summary

Motion
noise then quietness.

stunness

lyffam that appears to be lying face down may be asleep.

object
possibly a vehicle / machine

lyffam outside machine - it appears anyway.

heads of aol here

Very like a task I am doing for Dag - I may have displaced!



Aurora
Tundra
7:22
8:44

Es exposed
P exposed

Mrs. Bontto Baker
50° 40' N
008° 02' W
5 Sept 07
Wednesday
7-50 pm



Flat liner
Warm
Warmer
Hot
Goggles
See through
Stuffy
Large natural
mountain like
tingling
energetics



Small over curve horizontally down
to line across space in dot

7222 5444 n.

Mirror image
as above so below
Small subject
could be animal

Red & green
Foreign
heroglyph
Symbolic writing
opening
Medication
Appeture

Over curve to right
under curve ending in
teary tiny loop
as space in dot

2

Soft
Squishy

100 100 100 100
100 100 100 100
100 100 100 100

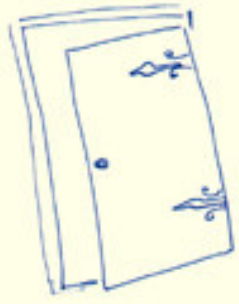

7222 8444 a.

Cleaned up
Stroke
huge change
Looking up
Narrow
Expansion of liquid
Shape
Strange subject

Looping to left, up over
to right down back
under curving the peak
tail going downwards

3

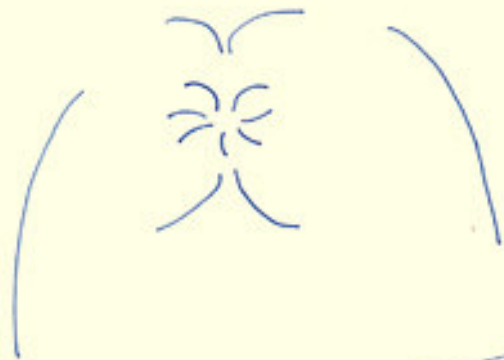

OC

Land mass
Visitor attraction
Seasonal
Tourist
Excitement
different
down under

Revelation
opening up

Coming out
differently

Rhyme
Story or information
Pictorial imagery
I.T.

Sam Sketch

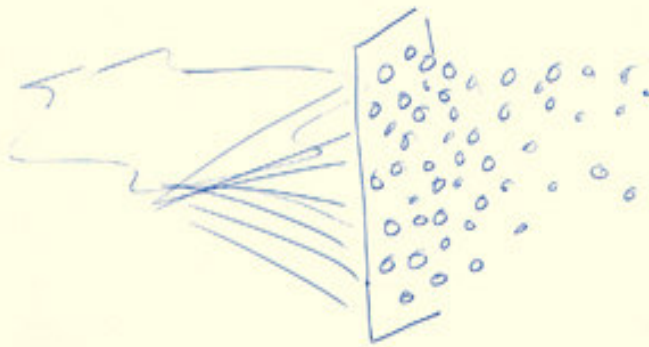

7222 5444 21.

6

dizzy
blurred vision
Eyepiece

Flat land with
a huge natural structure

the heights
Pointy thing

gone away
Protective wear
Sickly feeling
Pet dog?



7222 8444 ~.

Hidden
Revealed

Bimini
Gas exchange
Research
Carbonated
Lab.

Probe

Make a film of it

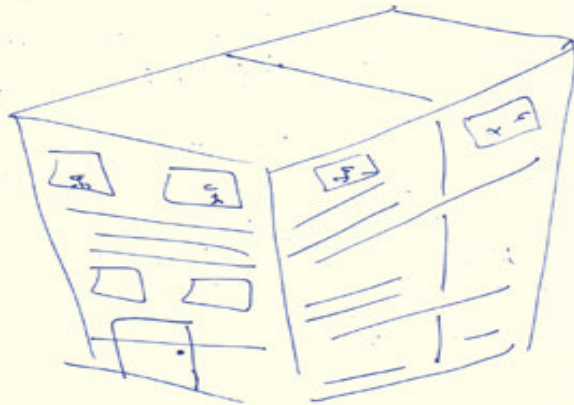

Session name: Tunde 7222

Date: 090507

Tasker: Tunde

Viewer: Jon

Monitor: —

Time Started: 8:57 am

Viewer mode: VB

Monitor mode: —

Tag: 7222-8444

Time Ended: 9:42 am

Conditions: Coffee
cat visit - brief

Cooldown used: Dirc 15 min.

Viewer intention/affirmation: I will view accurately.

transit

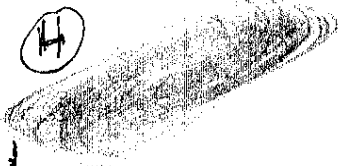

Scan 1:

7222 8444

A:

Density firm

B. Ideogram declaration:

land / flat surface

Playpen:

Topologicals



l.s. something rising from flat plane

C: Sensorals, magnitudes, energetics:

calm quiet

black, dark

musty (yellowish?)

windy?

D: Free draw or idea-driven

twist

[utter blackness]
"blank"

AOL: shard
on Moon

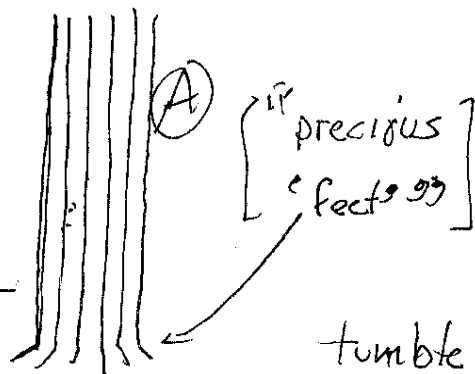

Scan 2: 7222 3444 ~~3444~~

Page 2

A: Density

B. Ideogram declaration
energy
Playpen:

musky (musty?)
forceful

"swirl-a-whirl"

Topologicals



inter-acting motions
(inward + around about)

C: Sensorals, magnitudes, energetics

(some energy under this)

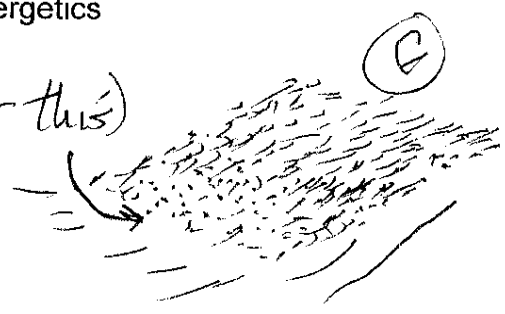

"like a 'sheet' of particles"

D: Free draw or idea-driven

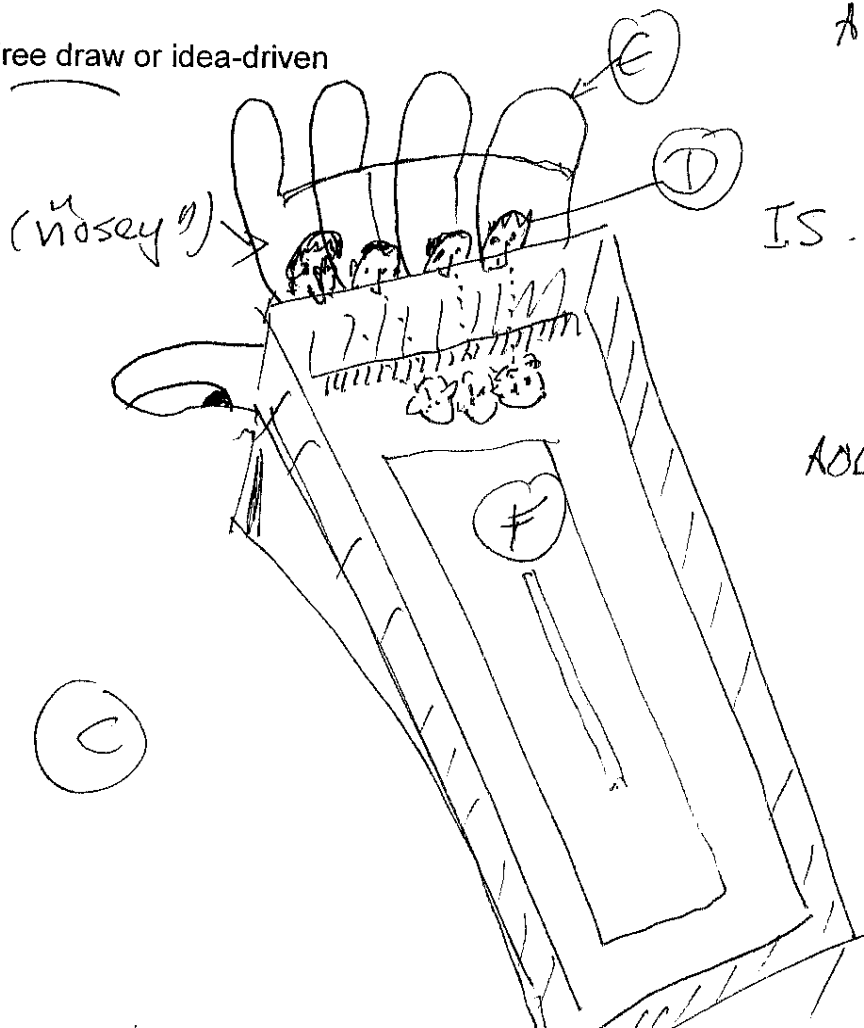

AOL: "Romper Room"
(TV program, old)

IS: "tarred + feathered"

AOL: "baker's dozen"
13

D: "cream-cake"

Scan 3:

722 844 

Page 3

A:
Density

light
dry

B. Ideogram declaration

none

Playpen:

Topologicals

gently up 

C: Sensorals, magnitudes, energetics

black, green, dark - Forceful now

rising

quiet

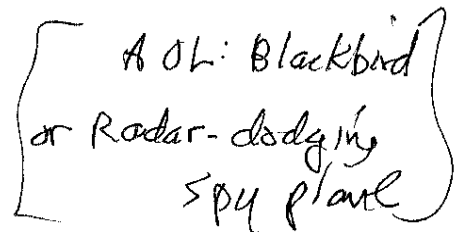
 AOL: Blackbird
or Radar-dodging
spy plane

D: Free draw or idea-driven

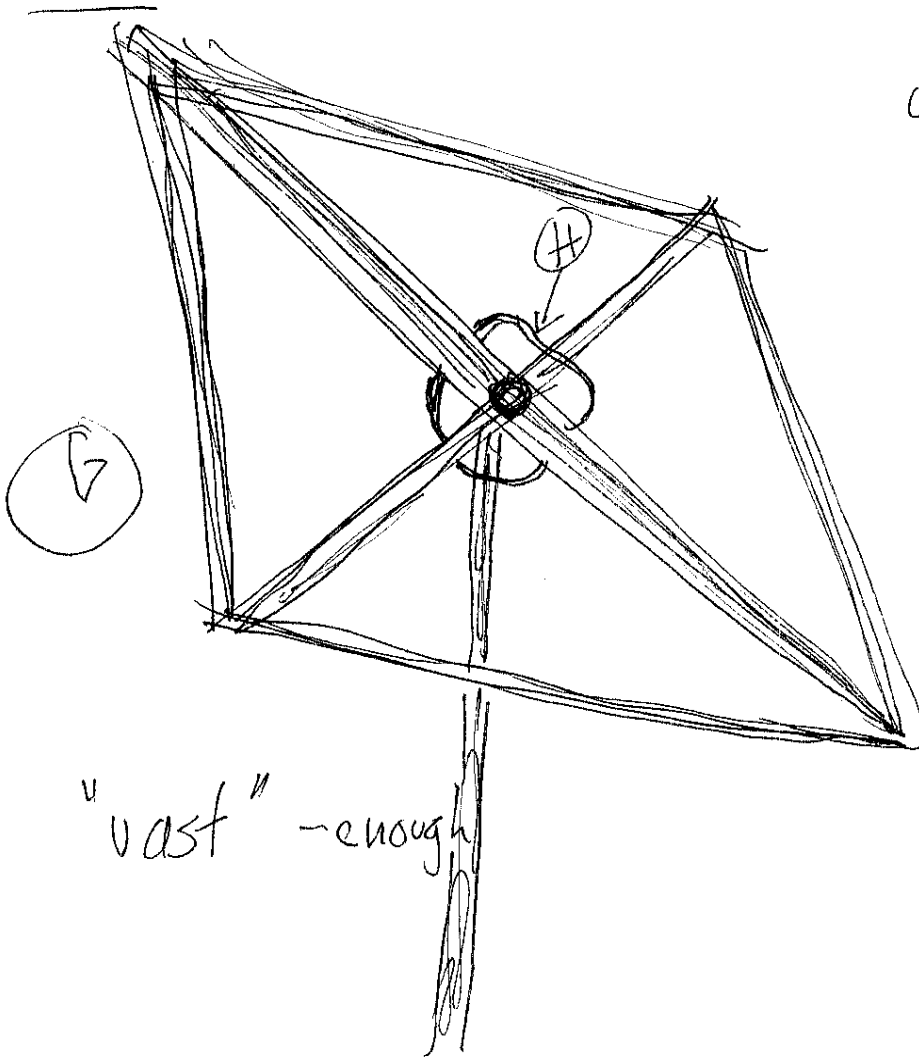

ungloved

"basted"

"windswept"

wind socket

hesitant

"sound each"

curmudgeon

"vast" - enough

Scan 1	COLLECTOR Scan 2	Page 4 Scan 3
7222-8444	7222 S.4.14	7222 8444*
vertical	black	cirring ¹
harvested	green (envy)	(Structure)
unambiguous	yielding ²	light
definite	subtle	revolves?
full throttle	not calculated (well)	
	unfrozen	unbending
		unyielding

Focus on most significant element or objective from taster's point
 of view: unyielding, mellow, "charmed, I'm sure"
 made well, made whole

What is most significant aspect so far not mentioned?

"Rolling..rolling..rolling.." (song by Creedence Clearwater)

MATRIX WORKSHEET:

Sensations	Magnitudes	Topology	Energy	Subjective	Physicals	Concepts	Symbolics
sense data e.g. colors, textures	directions, sizes: e.g. big, little, high, low	shapes, volumes e.g. flat, curved	types and levels, e.g. magnetic, radiating	mental states including emotions	structures or beings in any di- mension	ideas, patterns, etc.	images, symbols, also numbers

7222 8444



Structures

"class conflict"??



also enkh.

Probe person significant for this objective,
if any.

subcon

con

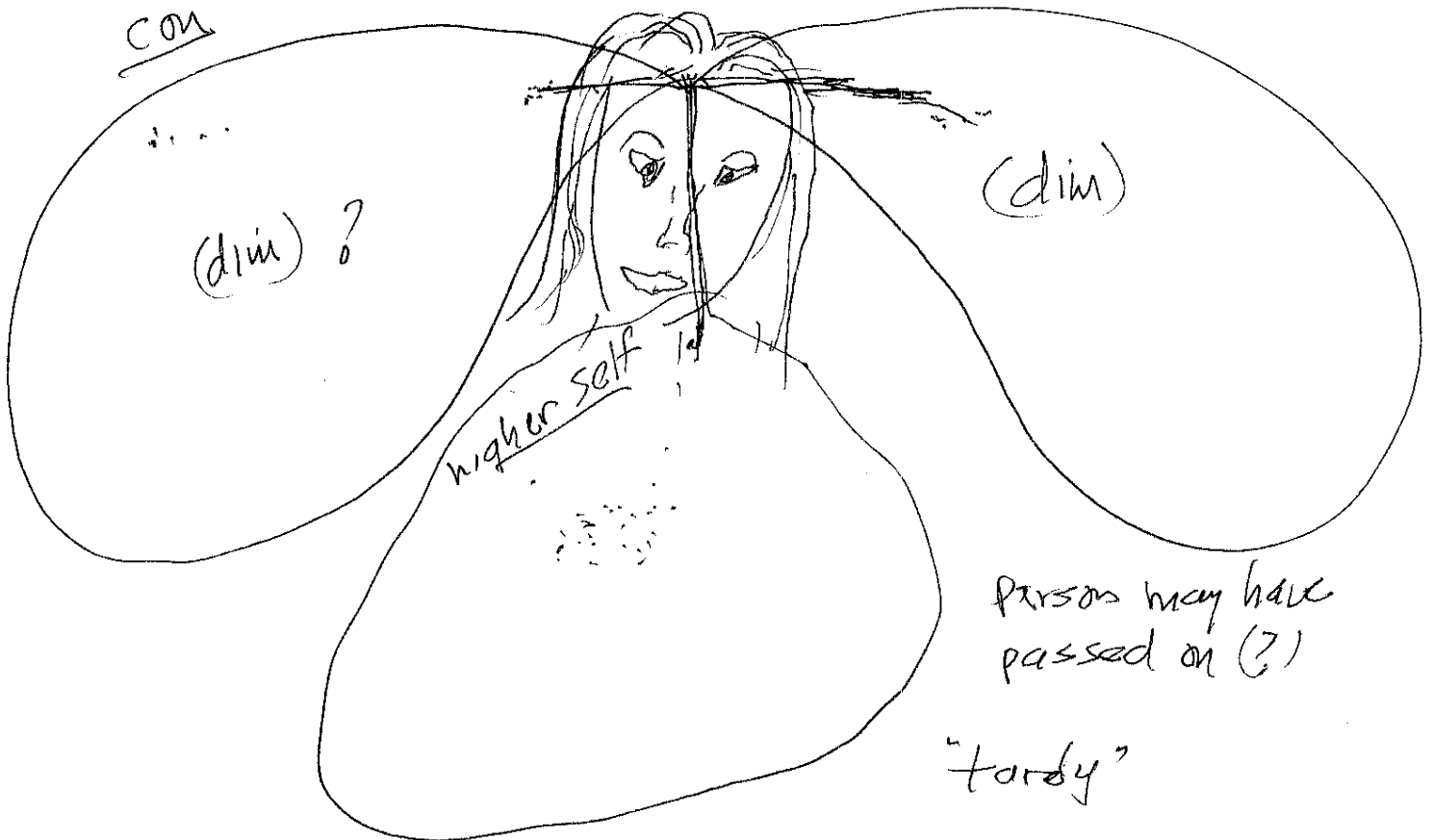

Person may have
passed on (?)

"tardy"

Page 6

Probe (B), page 1:



(No data)

Focus on (A), p. 1 + describe:



(tree-like)

PR: data seems to be drying up.

Focus on D-E-F, page 2 + describe:

My right hand wants to close slightly.

Focus on any energy stored in the objective + describe.



, as 's' = like (G), p. 2

What emotions are associated with this objective:

7222 5441 hardy² fed-up (longitudinal)upbeat cheerful cantankerous, also.

"remnants of desire" cherished, nourished

batle-worn.

Most important aspect of objective so far drawn?

(G), (H) (page 1) and (B) page 2

VIEWER SUMMARY

Page 7

This one has many facets, or so it seems.

- There seem to be energy + objects B + G
- (C), p. 2 may be symbolic/metaphorical.
- As to people, not much came (pages) but some emotions indicated on page 3 (right hand side) + page 6.
- Session may be conceptual (C) on page 2. with perhaps some literal elements (?) = (B).
- Started off with a flat plane + something rising upright on it (A), page 1.
- Session didn't flow well.
"You get what you get"

Summary
and session

7222B 8844B

T: T
V: Jan

9/5/07: 2¹⁰ pm Break; 2³² pm
Cooldown: Done.

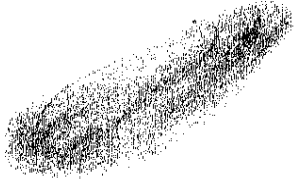

~~7222B~~ 7222B 8844B 

Focus on (G) in previous session:

(for) crying out (loud)

PR: I want to squeeze it together at $x' + x''$
" " " punch (H) "

Knob-like
manmade
"dusty"

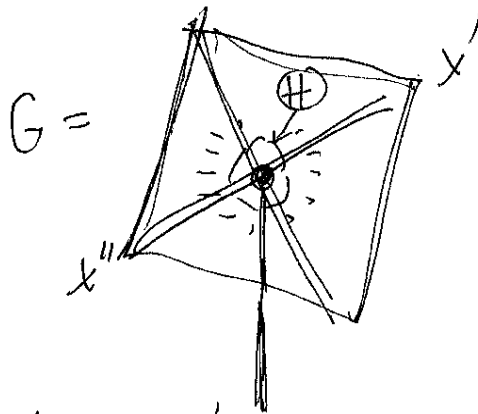

- energy coming off (H)
- rotates around knob

PR: I want to put my palm across
 $x' - x''$, fingers at 'y'

2

Probe (G)

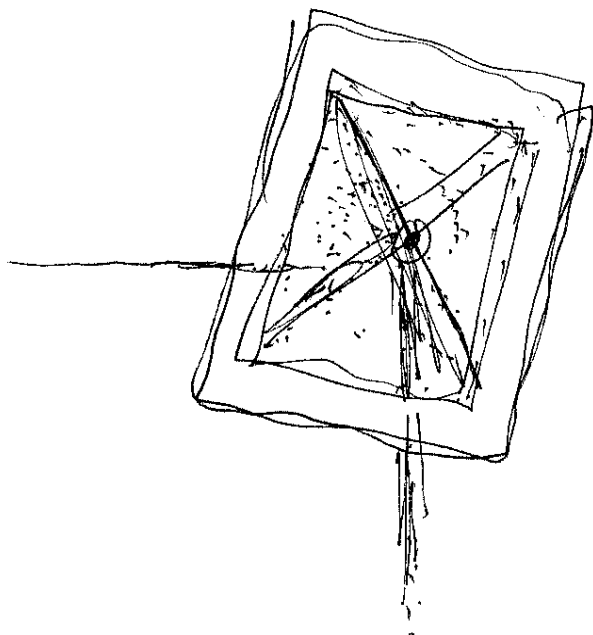

PR: "kite-like"

"duct tape"

"hand-swept"

"figor-ous"
"mortis"

What is purpose of (G)?

trading... treading... wind-blown

fierce
unyielding²

final
yielding
concomitant

"garbage"

"caught too soon"

⌘: spelunking
(cave)

⌘: mines in
cave-in

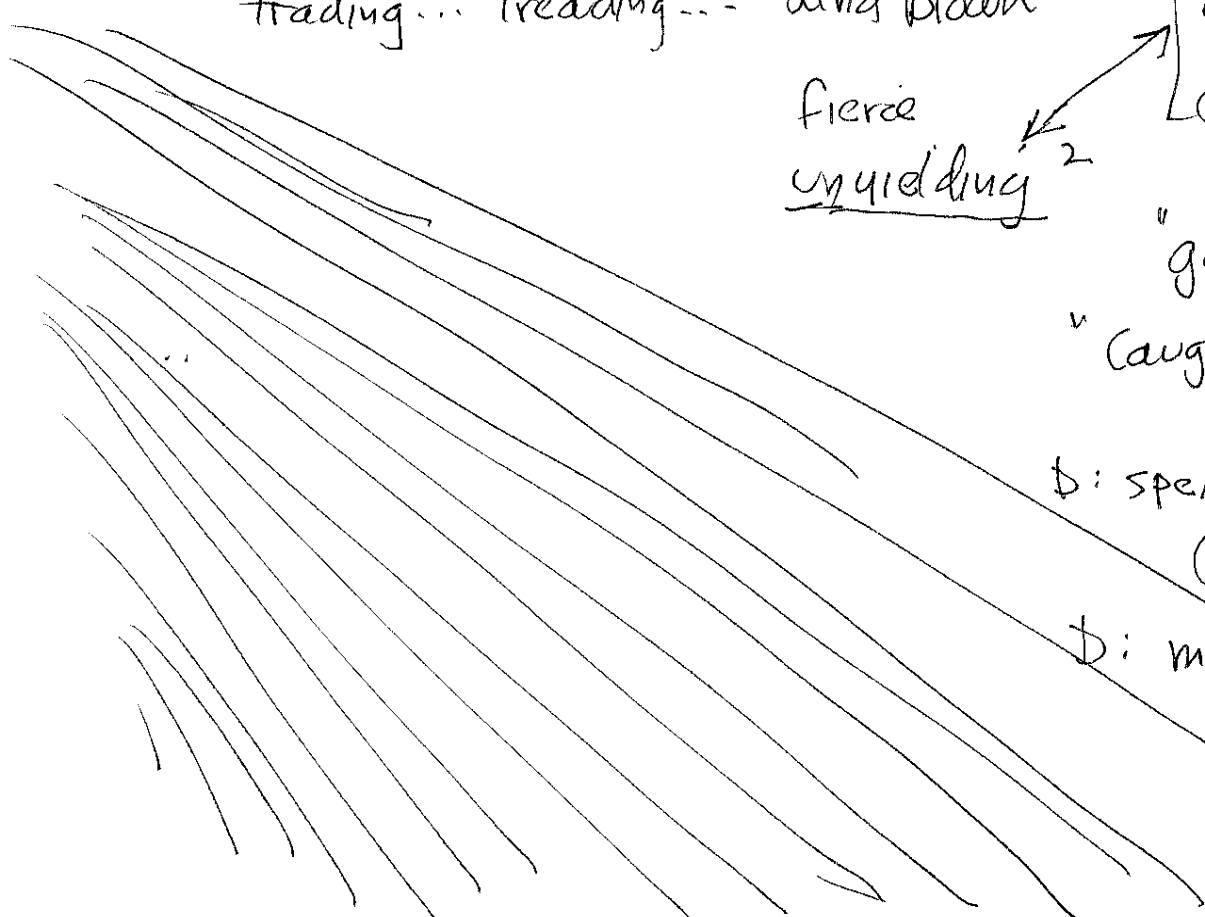

3

72228 8844B

B: Energy

Focus on (I) from other session, p. 5

Go to when she had conscious active at appropriate time for this tasking. (I)

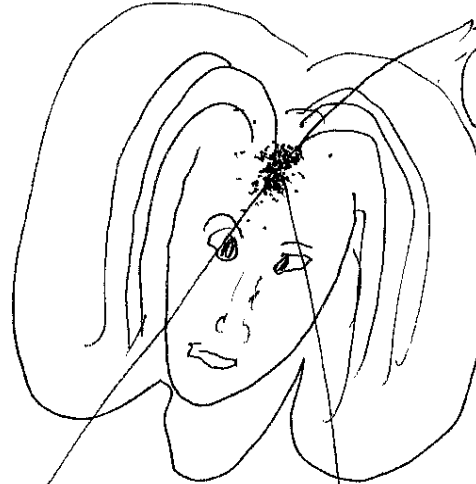

higher self
(Not verbal) But:
sense is like creature
does get 'squashed
like a fly' - hit from
the right, (Image)

Image: woman walking. Something comes in from her right, fast, dangerous. She needs to duck. It hits her (?).

note:
[cat visit]
now

can

[upbeat walking looking
hands at side looking
leftward} Fowweck!

subcon

Booger
meeting/mating?
"charmed, I'm sure"

"Not the way the
Bosphorus flows."

Too bad!

Excellent! an appeal. can get
it done.

dumb

yielding

caught flat-footed

(4)

Focus on old or data on page 5 + amplify:

(J) page 5:  ball, belt unyielding

[structures, heavier on
the right side] →

11 18 19 17 16 15 14 13 12 11 10 9 8 7 6 5 4 3 2 1

"ankh" =  (flying)

"cut throat"

[Break: 2:32 pm]

5

[Resume next morning at c. 8¹⁰ am]

7522B 8844B

~~7522B 8844B~~

green
blue

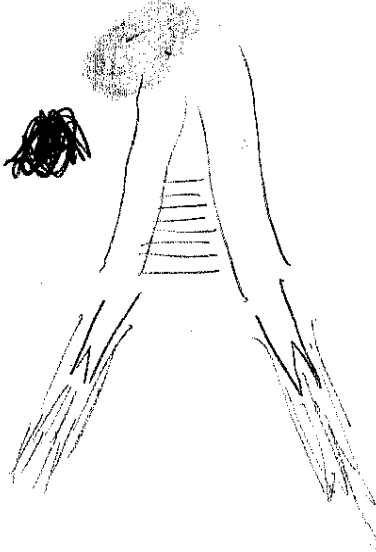

Plappen

"chuff"

"seen-through"

- topical

- aided

- barnstorming

Chicken-scraw

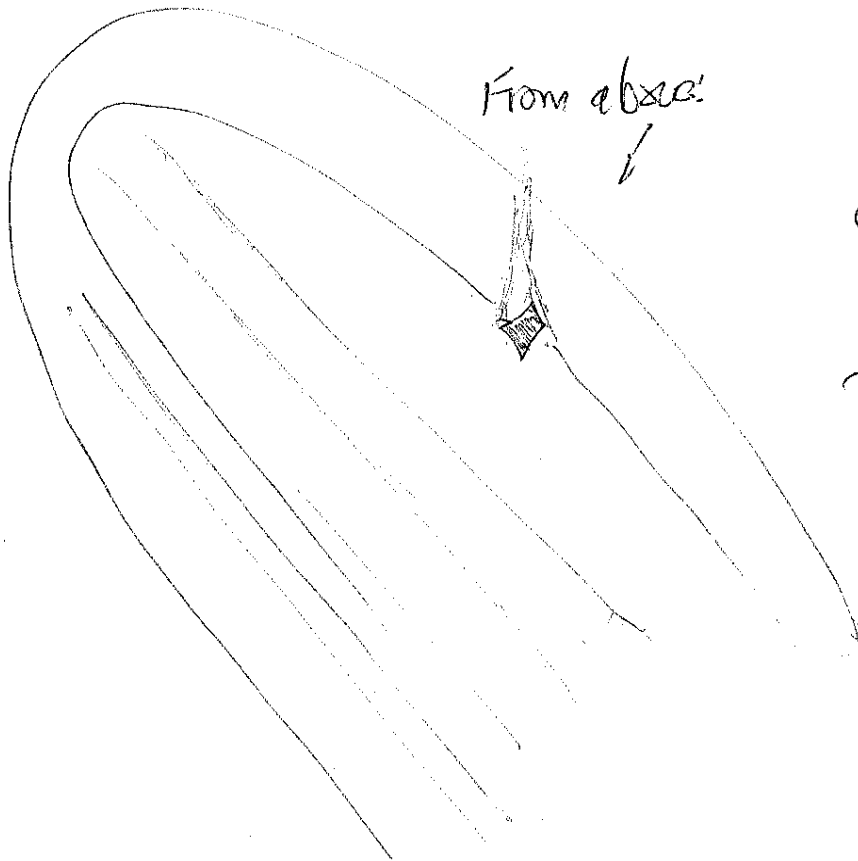

From above:

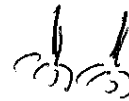

red rooster

on the table

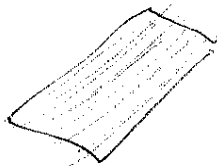

Lynley

AOL: Stanley Park
(B.C., Canada)

6

Focus anew on most important person re objective
to draw relevant info.



bottle-
stopper
plunger



"deep
sauce"

dihedron

[gash
two-fisted

Koh: Lahore,
Pakistan/
India

funneled
channel

7

Draw any relevant flags:

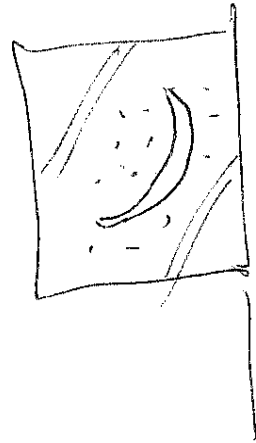
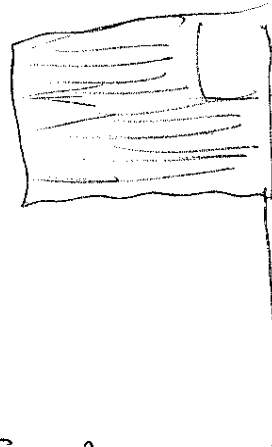

Relevant names:

Chul-ff
Charles
Cha...

Spate
Spekt
Speight

Sound-
oodles

Relevant countries - draw

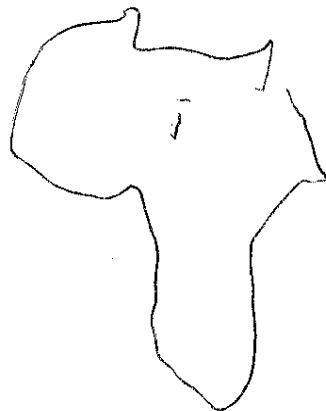

Africa

Relevant numbers: 6, 12, 21, 4, 8.

(8)

What is single most important thing I will
wish I had mentioned once I learn discovery/
disclosure - focus on + draw + word it

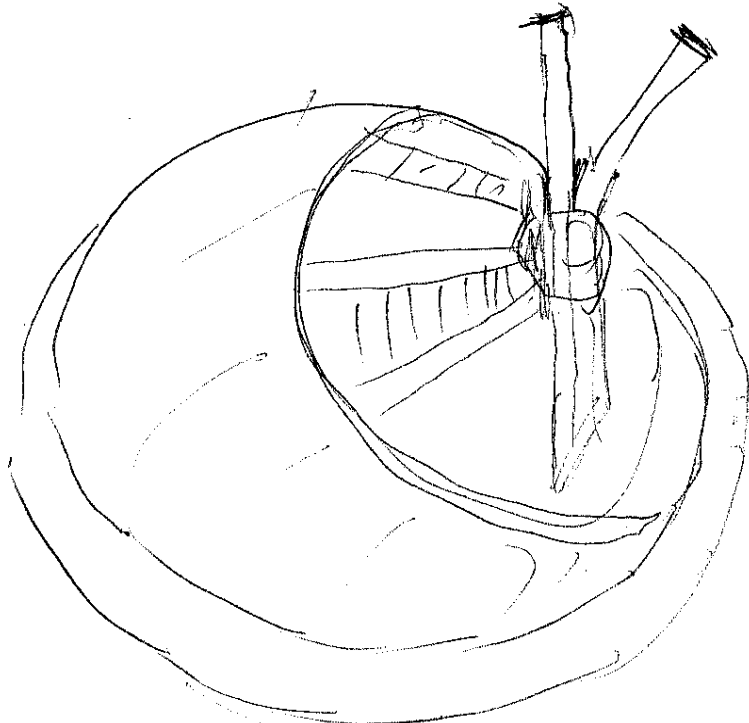

Selenium
(poison?)

Di Japan

"hold tight"

stairs

end addendum

g 32 dm

VB
Tunde's session

PS - full (stomach), feel good
ES - quiet, bland
Cooldown - meditation

Athens
5 Sept 7
11:52 am

7222

8444 ~~Structure~~ Structure

curved
heavy
stationary
large
metallic
outside

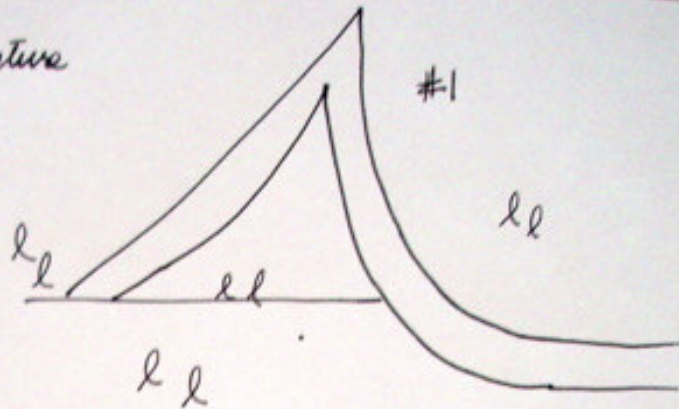

PR - like a huge sculpture

gray
moderate lighting
Ls nearby
hollow L
large / huge
dominating
smooth
cool
dirty tasting

PR - Ls can stand close to it, like the St. Louis Arch
other Ls nearby
manmade

7222

8444

subject

#2

heavy
S-humbled
soft
adult-sized
masculine



S-down-trodden; posture suggests low vitality or low emotions

outside
cool
e-fully clothed / clothed for cool weather
cloudy
gray
pollution smells
walking
moving
alone
heavy-set
middle aged
pale skin
breathing
PR-heavy-hearted / deflated

7222

8444

Subject

S

*3

3

grave

serious

heavy-set or dense physical body

masculine

PR - body is covered from head to toe

walking

movement is slow

smoky / Smoking smells

PR - I isn't particularly clear

outdoors

cool weather

PR - weight of the world's on his shoulders

urban area - area w/ Ls nearby

other Ls nearby

PR - I is lost in thought

humming

urban sounds

grayness around I

PR - dressed like a businessman - suit, overcoat,
hat



65

4

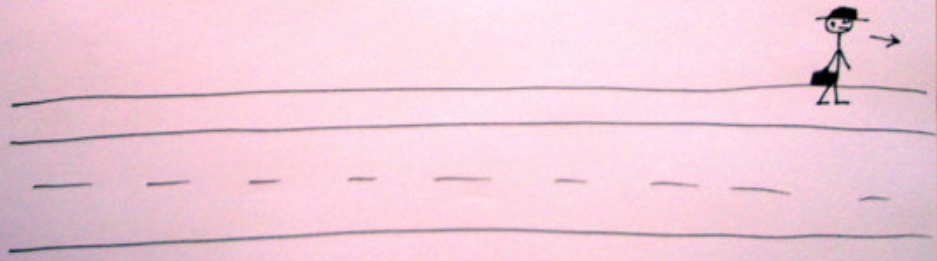
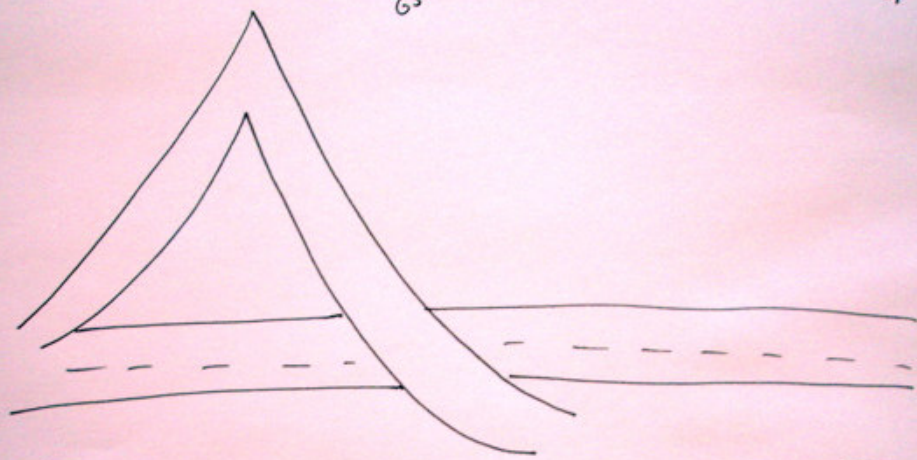

Blend w/ l and describe.

5

solitary l although others are around, walking, in a setting where there are a lot of ls and Ls, overcast/gray/cloudy weather, chilly, not particularly dapper - kind of ruffled and wrinkled as if it's at the end of the day, masculine, not in good physical shape - soft and a bit overweight, no worries about #, angry, upset, feels unjustified resentment towards himself, smart, knowledgeable, known more for his objectivity than subjectivity (head over heart), not cruel, not interested in metaphysics, W-dangler, upset about something

While blended, describe activity/event^{most} significant to l.

work isn't going well, lots of pressure, doesn't own the business where he works - he's one of many, uncertain of what to do about present situation - he could be in trouble, just angry, things will probably go on as they have before - this will pass, works primarily alone, moderately thought of by his peers - not very approachable, anger stands in his way of finding a solution - it's clouding his judgment. Unblend.

Shift to 250' above l and describe surroundings.

outdoors, chilly, damp, gray, not in the US - another (foreign) urban area, loud noises, lots of activity, ls walking along, area isn't necessarily a grid but it's well-laid out - open and not clustered or condensed like some urban areas can be, some industry, no large body of water nearby (like a lake)

Focus on what the tasker needs to know re: objective &
It will play itself out and be "behind" (or in the L's
past) the L soon, needs to overcome anger which
clouds his judgment, not as big of a deal as he thinks
it is, takes things too seriously, should look at re-
prioritizing what's important to him, work takes
priority over private life, keeps things in a lot which
is why he gets so unjustly angry, needs someone
neutral to talk to to get things off his mind and
not stew so much about the little things

[PR - this isn't someone I'd be interested in having
as a friend - totally different outlooks on life!]

End - 12²⁸ pm